

# Trade Price Book Addendum

Effective 5/1/2017



## Utica Heating Gas & Oil Fired Boilers

### Customer Service Technical Support

Phone: 800-325-5479  
Fax: 315-724-9319/866-432-7329  
[www.greenmountainboilers.com](http://www.greenmountainboilers.com)

### Corporate Sales

Phone: 877-386-5475  
Fax: 716-366-4670

### Literature

[literature@ecrinternational.com](mailto:literature@ecrinternational.com)



**ECR** international  
EST. 1928

A Family of Heating & Cooling Brands.

P/N 240011138 Addendum

**UH15B Series II**  
**NATURAL OR PROPANE**  
**HOT WATER BOILER**

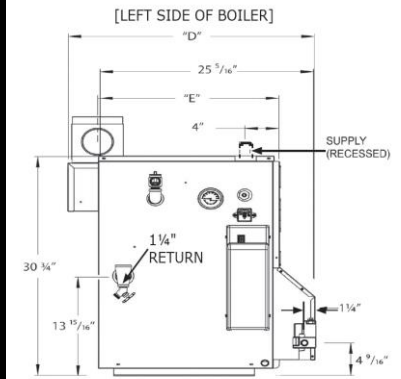
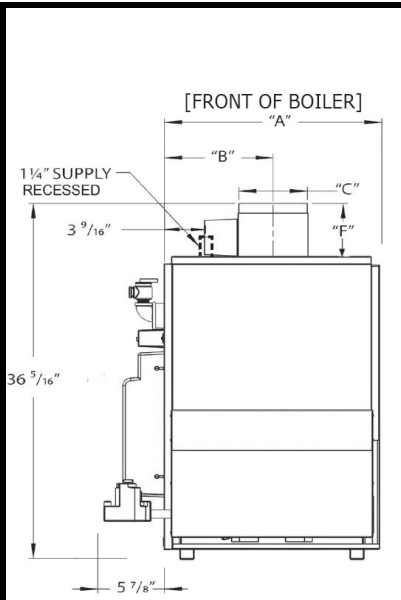
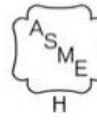

**General Information** (See IOM for complete instructions)

Clearances	Combustible Materials (Required) (1)	
<b>(1) Required distances measured from boiler.</b>	<b>Top</b>	18" (457 mm)
	<b>Front</b>	Alcove*
	<b>Flue Connector</b>	6" (152 mm)
	<b>Rear</b>	8" (203 mm)
	<b>Control Side</b>	9" (229 mm)
	<b>Other Side</b>	3" (76 mm)

\*Definition of Alcove is three sided space with no wall in front of boiler. ANSI standard for alcove is 18 inches from front of appliance to leading edge of side walls as shown in IOM.

Connections	Return/Supply Water	Gas In
UH15B045FE through UH15B195FE	1-1/4" NPT	1/2" NPT
UH15B245FE & UH15B295FE		3/4" NPT

**Electrical** 120 Volts AC, 60 hertz, 1 phase, Less than 12 amps (15 amp circuit recommended)

**Water Content** UH15B045FE - 2.4 Gallons, UH15B070FE/UH15B096FE - 4.0 Gallons, UH15B120FE/UH15B145FE - 5.6 Gallons, UH15B170FE/UH15B195FE - 7.2 Gallons, UH15B245FE - 8.8 Gallons, UH15B295FE - 10.4 Gallons

Dimensions						
Model	A	B	C	D	E	F
UH15B045FE	11-1/4"	5-5/8"	4"	27-1/8"	20-7/16"	4-15/16"
UH15B070FE	15-1/8"	7"	5"	28-1/8"	20-15/16"	4-15/16"
UH15B096FE	15-1/8"	7"	5"	28-1/8"	20-15/16"	4-15/16"
UH15B120FE	19"	9-1/2"	6"	29-1/8"	21-7/16"	5-7/16"
UH15B145FE	19"	9-1/2"	6"	29-1/8"	21-7/16"	5-7/16"
UH15B170FE	22-7/8"	11-3/16"	7"	30-1/8"	21-15/16"	5-15/16"
UH15B195FE	22-7/8"	11-3/16"	7"	30-1/8"	21-15/16"	5-15/16"
UH15B245FE	26-3/4"	13-6/16"	8"	31-1/8"	22-7/16"	6-15/16"
UH15B295FE	30-5/8"	15-5/16"	9"	32-1/8"	22-15/16"	8-15/16"

UH15B SERIES CONTINUED								
(NATURAL GAS - HONEYWELL WITH HYDROLEVEL LWCO CONTROL - TACO SYSTEM PUMP)								
BOILER MODEL	ITEM NUMBER	TRADE PRICE	INPUT (MBH)	HTG. CAP. (MBH)	AHRI NET (MBH)	AFUE RATING %	NO. OF BRNS.	SHIP WGT.
UH15B045FE	15B204503710209	\$1,811	45	37	32	82.0%	1	255
UH15B070FE	15B307003710209	\$1,932	70	57	50	82.0%	2	305
UH15B096FE	15B309603710209	\$2,038	96	79	69	82.0%	2	310
UH15B120FE	15B412003710209	\$2,242	120	98	85	82.0%	3	355
UH15B145FE	15B414503710209	\$2,383	145	119	103	82.0%	3	360
UH15B170FE	15B517003710209	\$2,678	170	140	122	82.0%	4	420
UH15B195FE	15B519503710209	\$2,968	195	160	139	82.0%	4	425
UH15B245FE	15B624503710209	\$3,242	245	201	174	82.0%	5	495
UH15B295FE	15B729503710209	\$3,458	295	242	210	82.0%	6	555
(NATURAL GAS - HONEYWELL WITH HYDROLEVEL LWCO CONTROL - GRUNDFOS SYSTEM PUMP)								
BOILER MODEL	ITEM NUMBER	TRADE PRICE	INPUT (MBH)	HTG. CAP. (MBH)	AHRI NET (MBH)	AFUE RATING %	NO. OF BRNS.	SHIP WGT.
UH15B045FE	15B204503720209	\$1,811	45	37	32	82.0%	1	255
UH15B070FE	15B307003720209	\$1,932	70	57	50	82.0%	2	305
UH15B096FE	15B309603720209	\$2,038	96	79	69	82.0%	2	310
UH15B120FE	15B412003720209	\$2,242	120	98	85	82.0%	3	355
UH15B145FE	15B414503720209	\$2,383	145	119	103	82.0%	3	360
UH15B170FE	15B517003720209	\$2,678	170	140	122	82.0%	4	420
UH15B195FE	15B519503720209	\$2,968	195	160	139	82.0%	4	425
UH15B245FE	15B624503720209	\$3,242	245	201	174	82.0%	5	495
UH15B295FE	15B729503720209	\$3,458	295	242	210	82.0%	6	555
(LP GAS - HONEYWELL WITH HYDROLEVEL LWCO CONTROL - TACO SYSTEM PUMP)								
BOILER MODEL	ITEM NUMBER	TRADE PRICE	INPUT (MBH)	HTG. CAP. (MBH)	AHRI NET (MBH)	AFUE RATING %	NO. OF BRNS.	SHIP WGT.
UH15B045FE	15B204513710209	\$1,858	45	37	32	82.0%	1	255
UH15B070FE	15B307013710209	\$2,016	70	57	50	82.0%	2	305
UH15B096FE	15B309613710209	\$2,086	96	79	69	82.0%	2	310
UH15B120FE	15B412013710209	\$2,290	120	98	85	82.0%	3	355
UH15B145FE	15B414513710209	\$2,431	145	119	103	82.0%	3	360
UH15B170FE	15B517013710209	\$2,726	170	140	122	82.0%	4	420
UH15B195FE	15B519513710209	\$3,016	195	160	139	82.0%	4	425
UH15B245FE	15B624513710209	\$3,290	245	201	174	82.0%	5	495
UH15B295FE	15B729513710209	\$3,506	295	242	210	82.0%	6	555
(LP GAS - HONEYWELL WITH HYDROLEVEL LWCO CONTROL - GRUNDFOS SYSTEM PUMP)								
BOILER MODEL	ITEM NUMBER	TRADE PRICE	INPUT (MBH)	HTG. CAP. (MBH)	AHRI NET (MBH)	AFUE RATING %	NO. OF BRNS.	SHIP WGT.
UH15B045FE	15B204513720209	\$1,858	45	37	32	82.0%	1	255
UH15B070FE	15B307013720209	\$1,980	70	57	50	82.0%	2	305
UH15B096FE	15B309613720209	\$2,086	96	79	69	82.0%	2	310
UH15B120FE	15B412013720209	\$2,290	120	98	85	82.0%	3	355
UH15B145FE	15B414513720209	\$2,431	145	119	103	82.0%	3	360
UH15B170FE	15B517013720209	\$2,726	170	140	122	82.0%	4	420
UH15B195FE	15B519513720209	\$3,016	195	160	139	82.0%	4	425
UH15B245FE	15B624513720209	\$3,290	245	201	174	82.0%	5	495
UH15B295FE	15B729513720209	\$3,506	295	242	210	82.0%	6	555

(USE PARTS MULTIPLIER FOR ALL OF THE FOLLOWING)	PN	TRADE
UH15B045FE NATURAL GAS TO LP GAS CONVERSION KIT	550001279	\$46
UH15B070FE NATURAL GAS TO LP GAS CONVERSION KIT	550001280	\$46
UH15B096FE NATURAL GAS TO LP GAS CONVERSION KIT	550001281	\$46
UH15B120FE NATURAL GAS TO LP GAS CONVERSION KIT	550001282	\$54
UH15B145FE NATURAL GAS TO LP GAS CONVERSION KIT	550001283	\$54
UH15B170FE NATURAL GAS TO LP GAS CONVERSION KIT	550001282	\$54
UH15B195FE NATURAL GAS TO LP GAS CONVERSION KIT	550001285	\$51
UH15B245FE NATURAL GAS TO LP GAS CONVERSION KIT	550001286	\$51
UH15B295FE NATURAL GAS TO LP GAS CONVERSION KIT	550001287	\$60
UH15B045FE LP GAS TO NATURAL GAS CONVERSION KIT	550001270	\$49
UH15B070FE LP GAS TO NATURAL GAS CONVERSION KIT	550001271	\$49
UH15B096FE LP GAS TO NATURAL GAS CONVERSION KIT	550001272	\$49
UH15B120FE LP GAS TO NATURAL GAS CONVERSION KIT	550001273	\$51
UH15B145FE LP GAS TO NATURAL GAS CONVERSION KIT	550001274	\$51
UH15B170FE LP GAS TO NATURAL GAS CONVERSION KIT	550001273	\$51
UH15B195FE LP GAS TO NATURAL GAS CONVERSION KIT	550001276	\$51
UH15B245FE LP GAS TO NATURAL GAS CONVERSION KIT	550001277	\$58
UH15B295FE LP GAS TO NATURAL GAS CONVERSION KIT	550001278	\$58
COMBUSTIBLE FLOOR PLATE FOR ALL CAPACITIES	14614032	\$96

**UH15B SERIES STANDARD EQUIPMENT**

**STANDARD EQUIPMENT:**

- Boiler Control Module: Honeywell Control with digital display and diagnostics, monitors water temperature and delays burner from starting until the residual heat energy within the boiler is consumed. Features a built-in low water cut-off (LWCO) to protect the boiler from potentially dangerous low water conditions.
- Heat Exchanger: Cast Iron Sections with Cast Iron Push Nipples.
- Combustion: Main Gas Burners, Combination 24 Volt Gas Control (Includes: Automatic Gas Valve, Gas Pressure Regulator, Intermittent Pilot, Safety Shutoff, Pilot Flow Adjustment, Pilot Filter)
- Safety: Spill Switch, Roll-Out Switch, Automatic Vent Damper.
- Other: Insulated Boiler Jacket, Integral Draft Diverter, Combination Temperature/Pressure Gauge, Circulator Pump, 3/4" Drain Valve, 30lb. ASME Relief Valve.