



# Trade Price Book 815

EFFECTIVE 8/24/2015



**SSC Wall-Hung Stainless Steel Modulating Condensing Boiler**

- 95% AFUE
- Available in 50 to 299 MBH
- Built-In Primary/Secondary Piping
- Built-in LWCO



**SSV Wall-Hung Stainless Steel Modulating Condensing Boiler**

- 95% AFUE
- Available in 50 to 200 MBH



**CuB Wall-Hung Copper Modulating Boiler**

- 85% AFUE
- Space Heating-Only & Combi Units



**MGB II / MGC Series Gas-Fired Water Boiler**

- Up to 83.9% AFUE
- Available in 50 to 299 MBH



**H2O Stainless Steel Indirect Water Heater**

- Easy to Install
- All Connections on Top
- Limited Lifetime Warranty (Residential)

**Customer Service  
Technical Support**

Phone: 800-325-5479  
Fax: 315-724-9319/866-432-7329  
www.uticaboilers.com

P/N 240005093 - 815, Rev. C

**Corporate Sales**

Phone: 877-386-5475  
Fax: 716-366-4670

**Literature**

literature@ecrinternational.com

*There are some things you can always depend on...*



**TABLE OF CONTENTS**

<b>Terms &amp; RMA Policy</b>	<b>3-4</b>
<b>Gas Condensing Boilers</b>	
SSC Stainless Steel Wall Hung Modulating Condensing Boiler	<b>5-7</b>
SSV Stainless Steel Wall Hung Modulating Condensing Boiler	<b>8-10</b>
UB90-100 Series IV Cast Aluminum Condensing Boiler	<b>11-13</b>
<b>Gas Modulating Space Heating Only &amp; Combi Boilers</b>	
CuB Copper Wall Hung Modulating Boiler	<b>14-15</b>
<b>Gas Cast Iron Boilers</b>	
SVB II Series	<b>16-19</b>
MGB II & MGC Series	<b>20-24</b>
PEG Series E	<b>25-26</b>
JE Steam	<b>27-29</b>
<b>Oil Cast Iron Boilers</b>	
TriFire TRB	<b>30-35</b>
SFH IV	<b>36-38</b>
SW II	<b>39-40</b>
SFE IV	<b>41-42</b>
BC Series II	<b>43-44</b>
<b>Indirect Hot Water Heaters</b>	
H2O Single Coil Stainless Steel Indirect Hot Water Heater	<b>45-46</b>
H2O Dual Coil Stainless Steel Indirect Hot Water Heater	<b>47-48</b>
H2O Storage Tanks	<b>49-50</b>
H2O Buffer Tanks	<b>51-52</b>
Hotline Indirect Water Heaters	<b>53</b>

**TERMS & CONDITIONS OF SALE - GENERAL TERMS**

**PRICES & SPECIFICATIONS:** All pricing and specifications subject to change without notice. The prices herein supersede all prior quotations.

**PAYMENT TERMS:** Net 30 Days

**ORDERS:** Orders will be accepted on the basis of prices in effect at the time the order is received. No order or contract will become an obligation on our part until accepted by the General Sales Department. ECR International shall not be liable for any delay or failure in the delivery or shipment of goods due to any cause or causes beyond its control.

**TAXES:** Add to the prices and terms quoted any manufacturers' or sales tax payable on the transaction under any effective statute.

**SHIPMENT**

**TRUCK LOADS:** \$40,000 Net Order Value - Freight Prepaid. Indirect Water Heaters and Commercial Boiler lines can be added to any residential order for freight purposes.

Authorized Distributors can combine Argo, Airco, Dunkirk, EMI, Olsen, Pennco and Utica and on one purchase order to earn free freight.

Stop off charges of \$150 will apply to stop off locations within 100 miles of final destination. Please call for pricing for stop off special handling for a location further than 100 miles or for special handling pricing for services such as lift gate, unloading assistance, etc.

**LESS THAN TRUCKLOAD SHIPMENT: F.O.B. ECR INTERNATIONAL - FACTORY OR WAREHOUSE**

**ORDER INFORMATION CHECKLIST**

The following information must be included on equipment or parts orders to insure proper shipment & invoicing:

- 1) Purchase Order Number
- 2) Bill To Address
- 3) Ship To Address
- 4) Method of Shipment (i.e. - trailer load, UPS, etc.)
- 5) Requested Ship Date
- 6) Special Instructions (i.e. - "Carrier to call...")
- 7) Pricing
- 8) Product Description (i.e. - Model, Size, Series, etc.)
- 9) Fuel Characteristics (i.e. Oil, Natural Gas, Propane)
- 10) Electrical Characteristics (i.e. - Operating Voltage, Cycles, Phases, etc.)
- 11) Non-Standard Equipment (Indicate "Optional" when substituted for standard equipment at extra cost listed. added to standard equipment).
- 12) Kits or Parts (Orders for kits or parts must indicate equipment size and series).
- 13) Send orders to:

**E-Mail: [ecrorderentry@ecrinternational.com](mailto:ecrorderentry@ecrinternational.com)**

**Fax: 315-724-9319**

- 14) Please note the following Remit To Address:

**ECR International, Inc.  
P.O. Box 8000 Department 039  
Buffalo, NY 14267**

Continued on Next Page

**TERMS & CONDITIONS OF SALE - GENERAL TERMS CONTINUED**  
**U.S. DISTRIBUTOR - RETURN MATERIAL POLICY - EFFECTIVE 8/18/2014**

To assist in providing the best service to our valued customers, ECR International has developed the following guidelines to help you in the unlikely event that you will need to return merchandise purchased from us. These guidelines have been developed after carefully reviewing common industry practice. We trust that you find them fair and easy to follow.

**Prior Approval Required** - All returns for exchange, credit, repair service or warranty claim must be approved by ECR and require an RMA number prior to return of the material. A request must be completed via ECR International's online web portal. Please log on to [www.ecrcustomerportal.com](http://www.ecrcustomerportal.com) (hyperlink below) to complete your request for return. If you do not already have access to the customer web portal please contact ECR Customer Service at 1-800-325-5479 to be set-up.

**Eligibility** - An RMA Request must be received within 60 days from the date of invoice for returns of New & Unused product in original packaging. A restocking fee of 15% will be charged for all new and unused returns that are approved for return. Special Order Products (items not offered as standard in ECR trade price book) are not eligible for return as new and unused product. Request for Warranty Returns must be made within the period covered by the warranty and must fall under the terms and conditions specified in the warranty.

**Repair Service** - Request for repair or rework of product damaged by customer is classified as Repair Service. Repair Service is billed at \$75.00 per hour for labor and net price for parts used in repair/rework. ECR's Return Material (RM) department will evaluate the items returned for repair service. The customer will receive an estimate for the dollar amount, determined by ECR's RM department, required to complete the repairs requested. A Purchase Order (PO) from the customer for that amount will be required before any work is performed.

**RMA Expiration** - Once the RMA number is issued, the product must be returned within 90 days of the RMA date, or the RMA will be canceled. Products approved for return that are received after 90 days from the RMA date will not be accepted.

**Shipping & Packaging** - All returns must have a valid RMA number clearly displayed on the exterior of the package or the package will not be accepted. All returns of new and unused product must be in the original packaging. All returns must be shipped prepaid by the customer unless otherwise directed by ECR as indicated on the RMA Verification. Ship all approved return material to the facility indicated on the approved RMA Request by the date indicated.

**Replacement Product** - If replacement product is desired it must be indicated on the RMA Request. A PO# is required for the replacement shipment and must be indicated on the RMA Request. All replacement products will be invoiced at the time of shipment. ECR will pay the ground freight for all warranty replacements.

**Application of Credit** - Credit for returned product will be applied to the customer's account (less restocking fees for New and Unused returns) only after confirmation of receipt by ECR and inspection of the product. Issuance of a credit for a partial return of product does not relieve the customer from the obligation to remit payment for the merchandise not returned in accordance with the payment terms referenced on the customer's invoice(s). Customer will have the option to have any product that is denied for credit returned at their expense.

<http://www.ecrcustomerportal.com>

**SSC SERIES**

NATURAL OR PROPANE  
MODULATING CONDENSING  
HOT WATER BOILER

150 psi  
MAWP

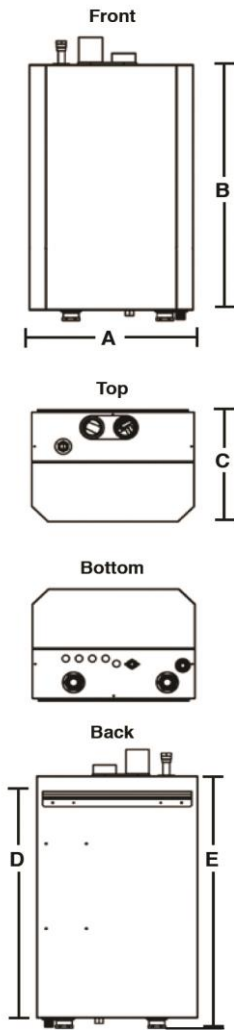
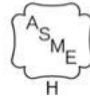

All SSC models have an AFUE of 95% and meet the criteria for 2015 Most Efficient.



**General Information** (See IOM for complete instructions)

Clearances	Combustible Materials (Required) (1)		Service (2)			
	(1) Required distances measured from boiler.	Top	0" (0 cm)	14" (36 cm)		
Left Side		0" (0 cm)	0" (0 cm)			
Right Side		0" (0 cm)	0" (0 cm)			
Front		0" (0 cm)	6" (16 cm)			
Back		0" (0 cm)	0" (0 cm)			
Bottom		0" (0 cm)	12" (32 cm)			
(2) Service, proper operation clearance recommended.	Combustion Air/Vent Piping	0" (0 cm)	6" (16 cm)			
	Hot Wat. Piping	See Local Code	6" (16 cm)			
Combustion Air & Vent Pipe Equiv. Length	(Schedule 40 PVC)					
	2" Pipe		3" Pipe		4" Pipe	
	50	75/100	75/100	150/200	299	299
Min. Length	6 Ft.	6 Ft.	6 Ft.	6 Ft.	6 Ft.	6 Ft.
	(1.8 m)	(1.8 m)	(1.8 m)	(1.8 m)	(1.8 m)	(1.8 m)
Max. Length	100 Ft.	50 Ft.	100 Ft.	100 Ft.	25 Ft.	100 Ft.
	(30.5 m)	(15.2 m)	(30.5 m)	(30.5 m)	(7.7 m)	(30.5 m)

**Dimensions**

Models	050	150
	075	200
	100	*299
Width "A"	20"	23"
	508 mm	584 mm
Height "B"	30"	40"
	762 mm	1016 mm
*Depth "C"	14"	*16"
	356 mm	406 mm
Bracket "D"	28"	40"
	711 mm	1016 mm
Ht. w/Piping "E"	31"	42"
	787 mm	1092 mm

**Note: Refer to IOM and vent pipe manufacturer's instructions for equivalent vent lengths and alternate venting materials.**

Connections	Return/Supply Water	Gas In	Cond. Drain
<b>050/075/100</b>	1-1/4" NPT	1/2" NPT	3/4" NPT
<b>150/200/299</b>	1-1/4" NPT	3/4" NPT	3/4" NPT
<b>Electrical</b>	120 Volts AC, 60 hertz, 1 phase, Less than 12 amps (15 amp circuit recommended)		
<b>Water Content</b>	050/075/100 - 1.1 Gallons, 150/200/299 - 1.8 Gallons		
*299 Dimensions are the same as 150/200 models <b>except</b> for Depth which is 18.3"/465 mm for the 299 model.			

SSC SERIES CONTINUED								
(NATURAL GAS - LESS SYSTEM PUMP)								
BOILER MODEL	ITEM NUMBER	TRADE PRICE	INPUT (MBH) MAX/ MIN	HTG. CAP. (MBH)	AHRI NET (MBH)	AFUE RATING %	FLUE DIA.	BLR./ SHP WGT. LBS.
UBSSC-50	UBSSCA050NA0AAA	\$4,705	50/10	46	40	95	2"	91/111
UBSSC-75	UBSSCA075NA0AAA	\$4,775	75/15	69	60	95	2" or 3"	91/111
UBSSC-100	UBSSCA100NA0AAA	\$4,965	100/20	91	79	95	2" or 3"	91/111
UBSSC-150	UBSSCA150NA0AAA	\$5,989	150/30	139	121	95	3"	157/182
UBSSC-200	UBSSCA200NA0AAA	\$6,422	200/40	185	161	95	3"	157/182
UBSSC-299	UBSSCA299NA0AAA	\$9,411	299/60	273	239	95	3" or 4"	195/225
(NATURAL GAS - WITH TACO SYSTEM PUMP)								
BOILER MODEL	ITEM NUMBER	TRADE PRICE	INPUT (MBH) MAX/ MIN	HTG. CAP. (MBH)	AHRI NET (MBH)	AFUE RATING %	FLUE DIA.	BLR./ SHP WGT. LBS.
UBSSC-50	UBSSCA050NA1AAA	\$4,858	50/10	46	40	95	2"	91/111
UBSSC-75	UBSSCA075NA1AAA	\$4,928	75/15	69	60	95	2" or 3"	91/111
UBSSC-100	UBSSCA100NA1AAA	\$5,118	100/20	91	79	95	2" or 3"	91/111
UBSSC-150	UBSSCA150NA1AAA	\$6,142	150/30	139	121	95	3"	157/182
UBSSC-200	UBSSCA200NA1AAA	\$6,575	200/40	185	161	95	3"	157/182
(NATURAL GAS - WITH GRUNDFOS SYSTEM PUMP)								
BOILER MODEL	ITEM NUMBER	TRADE PRICE	INPUT (MBH) MAX/ MIN	HTG. CAP. (MBH)	AHRI NET (MBH)	AFUE RATING %	FLUE DIA.	BLR./ SHP WGT. LBS.
UBSSC-50	UBSSCA050NA3AAA	\$4,858	50/10	46	40	95	2"	91/111
UBSSC-75	UBSSCA075NA3AAA	\$4,928	75/15	69	60	95	2" or 3"	91/111
UBSSC-100	UBSSCA100NA3AAA	\$5,118	100/20	91	79	95	2" or 3"	91/111
UBSSC-150	UBSSCA150NA3AAA	\$6,142	150/30	139	121	95	3"	157/182
UBSSC-200	UBSSCA200NA3AAA	\$6,575	200/40	185	161	95	3"	157/182
Note: The UB SSC299 is only available less system pump.								

<b>SSC SERIES CONTINUED</b>		
<b>SSC SERIES - VENTING OPTIONS/ADDITIONAL EQUIPMENT (USE PARTS MULTIPLIER)</b>	<b>PN</b>	<b>TRADE</b>
<b>050 NATURAL TO LP AND LP TO NATURAL GAS CONVERSION KIT</b>	<b>550002303</b>	<b>\$46</b>
<b>075 NATURAL TO LP AND LP TO NATURAL GAS CONVERSION KIT</b>	<b>550002304</b>	<b>\$46</b>
<b>100 NATURAL TO LP AND LP TO NATURAL GAS CONVERSION KIT</b>	<b>550002305</b>	<b>\$46</b>
<b>150 NATURAL TO LP AND LP TO NATURAL GAS CONVERSION KIT</b>	<b>550002306</b>	<b>\$46</b>
<b>200 NATURAL TO LP AND LP TO NATURAL GAS CONVERSION KIT</b>	<b>550002307</b>	<b>\$46</b>
<b>299 NATURAL TO LP AND LP TO NATURAL GAS CONVERSION KIT</b>	<b>550002799</b>	<b>\$48</b>
<b>2" CONCENTRIC VENT KIT</b>	<b>29570</b>	<b>\$218</b>
<b>3" CONCENTRIC VENT KIT</b>	<b>29571</b>	<b>\$218</b>
<b>MULTIPLE BOILER SENSOR KIT</b>	<b>550002186</b>	<b>\$78</b>
<b>FLOOR STAND KIT</b>	<b>240010266</b>	<b>\$587</b>

**SSC SERIES - STANDARD EQUIPMENT**

**STANDARD EQUIPMENT:**

- Wall Mounted: Bracket included.
- Boiler Control Module: Automatic Low Voltage/Intermittent Direct Spark Ignition/Modulating with a 5:1 combustion turn down ratio. For multiple boiler applications - the control module can stage up to 16 boilers.
- User Display interface: Easy programming with text display. Remote mount option utilizes standard thermostat conductor wiring. Outdoor Temperature Sensor included.
- Heat Exchanger: High grade 316L/444 Stainless Steel Fin Coil with Flame Sight Glass.
- Built-in Primary/Secondary Manifold Piping and Pump.
- Combustion: Gas Valve with Premix Venturi and Blower, Durable Stainless Steel Mesh Modulating Burner with 5:1 turn down ratio, Direct Spark Igniter, Flame Sensor and LP Conversion Kit included.
- Electrical: Detachable Low Voltage Terminal Strip, High Voltage Junction Box and Transformer.
- Other: Factory installed probe-type Low Water Cut Off with test feature, 30 PSI Safety Relief Valve, Boiler Drain Valve and Condensate Drain with built in trap.

**SSV SERIES**

NATURAL OR PROPANE  
MODULATING CONDENSING  
HOT WATER BOILER

150 psi  
MAWP

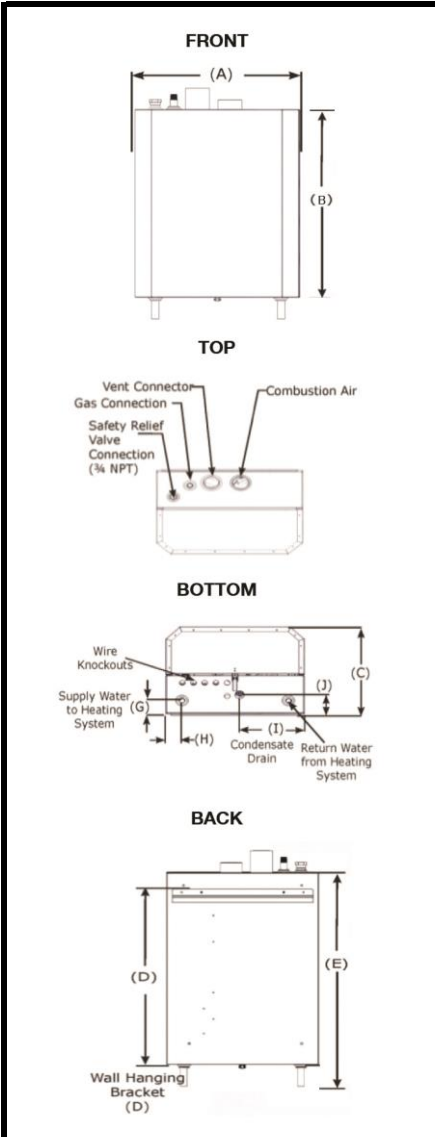
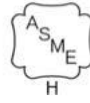

All SSV models have an AFUE of 95% and meet the criteria for 2015 Most Efficient.



**General Information** (See IOM for complete instructions)

Clearances	Combustible Materials (Required) (1)		Service (2)	
	<b>(1) Required distances measured from boiler jacket.</b>	<b>Top</b>	0" (0 cm)	14" (36 cm)
<b>Left Side</b>		0" (0 cm)	0" (0 cm)	
<b>Right Side</b>		0" (0 cm)	0" (0 cm)	
<b>Front</b>		0" (0 cm)	6" (16 cm)	
<b>Back</b>		0" (0 cm)	0" (0 cm)	
<b>Bottom</b>		0" (0 cm)	12" (32 cm)	
<b>(2) Service, proper operation clearance recommended.</b>	<b>Combustion Air/Vent Piping</b>	0" (0 cm)	6" (16 cm)	
	<b>Hot Wat. Piping</b>	See Local Code	6" (16 cm)	
<b>Combustion Air &amp; Vent Pipe Equiv. Length</b>	(Schedule 40 PVC)			
	<b>2" Pipe</b>		<b>3" Pipe</b>	
	<b>50</b>	<b>75/100</b>	<b>75/100</b>	<b>150/200</b>
Min. Length	6 Ft. (1.8 m)	6 Ft. (1.8 m)	6 Ft. (1.8 m)	6 Ft. (1.8 m)
	100 Ft. (30.5 m)	50 Ft. (15.2 m)	100 Ft. (30.5 m)	100 Ft. (30.5 m)

Dimensions		
<b>Models</b>	050	150
	075	200
	100	200
Width "A"	20"	23"
	508 mm	584 mm
Height "B"	27.75"	37.75"
	705 mm	959 mm
Depth "C"	14.75"	16.3"
	375 mm	414 mm
Bracket "D"	24.41"	35.6"
	620 mm	904 mm
Ht. w/Piping "E"	30.75"	40.75"
	781 mm	104 cm

**Note: Refer to IOM and vent pipe manufacturer's instructions for equivalent vent lengths and alternate venting materials.**

Connections	Return/Supply Water	Gas In	Cond. Drain
<b>050/075/100</b>	3/4" Copper Stub	1/2" NPT	3/4" NPT
<b>150/200</b>	1" Copper Stub	3/4" NPT	3/4" NPT
<b>Electrical</b>	120 Volts AC, 60 hertz, 1 phase, Less than 12 amps (15 amp circuit recommended)		
<b>Water Content</b>	050/075/100 - 1.1 Gallons, 150/200 - 1.8 Gallons		



SSV SERIES CONTINUED								
(NATURAL GAS - LESS SYSTEM PUMP)								
BOILER MODEL	ITEM NUMBER	TRADE PRICE	INPUT (MBH) MAX/ MIN	HTG. CAP. (MBH)	AHRI NET (MBH)	AFUE RATING %	FLUE DIA.	BLR./ SHP WGT. LBS.
SSV-50	SSV105003500110	\$3,793	50/10	46	40	95	2"	91/111
SSV-75	SSV107503500110	\$3,897	75/15	69	60	95	2"	91/111
SSV-100	SSV110003500110	\$4,087	100/20	91	79	95	2"	91/111
SSV-150	SSV115003500110	\$5,226	150/30	139	121	95	3"	157/182
SSV-200	SSV120003500110	\$5,418	200/40	185	161	95	3"	157/182
(NATURAL GAS - TACO SYSTEM PUMP)								
BOILER MODEL	ITEM NUMBER	TRADE PRICE	INPUT (MBH) MAX/ MIN	HTG. CAP. (MBH)	AHRI NET (MBH)	AFUE RATING %	FLUE DIA.	BLR./ SHP WGT. LBS.
SSV-50	SSV105003510110	\$3,933	50/10	46	40	95	2"	91/111
SSV-75	SSV107503510110	\$4,037	75/15	69	60	95	2"	91/111
SSV-100	SSV110003510110	\$4,227	100/20	91	79	95	2"	91/111
SSV-150	SSV115003510110	\$5,366	150/30	139	121	95	3"	157/182
SSV-200	SSV120003510110	\$5,558	200/40	185	161	95	3"	157/182
(NATURAL GAS - GRUNDFOS SYSTEM PUMP)								
BOILER MODEL	ITEM NUMBER	TRADE PRICE	INPUT (MBH) MAX/ MIN	HTG. CAP. (MBH)	AHRI NET (MBH)	AFUE RATING %	FLUE DIA.	BLR./ SHP WGT. LBS.
SSV-50	SSV105003520110	\$3,933	50/10	46	40	95	2"	91/111
SSV-75	SSV107503520110	\$4,037	75/15	69	60	95	2"	91/111
SSV-100	SSV110003520110	\$4,227	100/20	91	79	95	2"	91/111
SSV-150	SSV115003520110	\$5,366	150/30	139	121	95	3"	157/182
SSV-200	SSV120003520110	\$5,558	200/40	185	161	95	3"	157/182

<b>SSV SERIES CONTINUED</b>		
<b>SSV SERIES - VENTING OPTIONS/ADDITIONAL EQUIPMENT (USE PARTS MULTIPLIER)</b>	<b>PN</b>	<b>TRADE</b>
050 NATURAL TO LP AND LP TO NATURAL GAS CONVERSION KIT	550002303	\$46
075 NATURAL TO LP AND LP TO NATURAL GAS CONVERSION KIT	550002304	\$46
100 NATURAL TO LP AND LP TO NATURAL GAS CONVERSION KIT	550002305	\$46
150 NATURAL TO LP AND LP TO NATURAL GAS CONVERSION KIT	550002306	\$46
200 NATURAL TO LP AND LP TO NATURAL GAS CONVERSION KIT	550002307	\$46
2" CONCENTRIC VENT KIT	29570	\$218
3" CONCENTRIC VENT KIT	29571	\$218
MULTIPLE BOILER SENSOR KIT	550002186	\$78
FLOOR STAND KIT	240010266	\$587

**SSV SERIES - STANDARD EQUIPMENT**

**STANDARD EQUIPMENT:**

- Wall Mounted: Bracket included.
- Boiler Control Module: Automatic Low Voltage/Intermittent Direct Spark Ignition/Modulating with a 5:1 combustion turn down ratio. For multiple boiler applications - the control module can stage up to 16 boilers.
- User Display interface: Easy programming with text display. Remote mount option utilizes standard thermostat conductor wiring. Outdoor Temperature Sensor included.
- Heat Exchanger: High grade 316L/444 Stainless Steel Fin Coil with Flame Sight Glass.
- Combustion: Gas Valve with Premix Venturi and Blower, Durable Stainless Steel Mesh Modulating Burner with 5:1 turn down ratio, Direct Spark Igniter, Flame Sensor.
- Electrical: Low Voltage Terminal Strip, High Voltage Junction Box and Transformer.
- Other: 30 PSI Safety Relief Valve, Boiler Drain Valve and Condensate Drain with built in trap.

**UB90-100 SERIES IV**

NATURAL OR PROPANE  
CONDENSING HOT WATER BOILER

50 psi  
MAWP

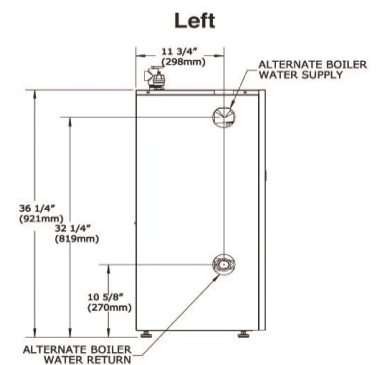
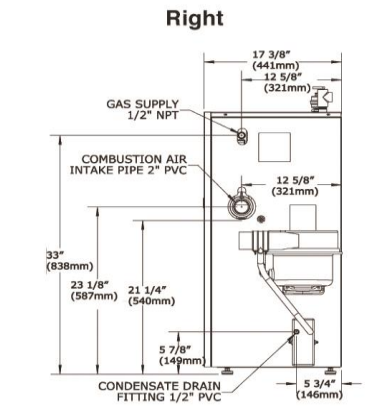
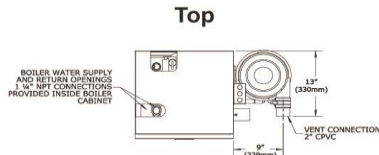
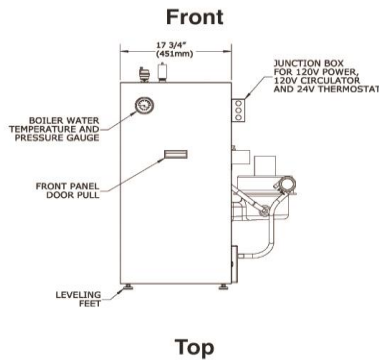

**General Information** (See IOM for complete instructions)

Clearances	Combustible Materials				Service (2)
	(Required) (1)				
(1) Required distances measured from boiler.	Top	1" (26 mm)		8" (204 mm)	
	Left Side	1" (26 mm)		N/A	
	Right Side	11" (280 mm)		N/A	
	Base	1" (26 mm)		N/A	
	Front	1" (26 mm)		24" (610 mm)	
	Back	1" (26 mm)		N/A	
(2) Service, proper operation clearance recommendation.	Combustion Air/Vent Piping	0" (0 mm)		N/A	
Combustion Air & Vent Pipe Equivalent Length (Schedule 40 PVC)	2" Pipe	050	100	050	100
		075		075	
	Min. Length	2 Ft.	2 Ft.	20 Ft.	15 Ft.
		(.61 m)	(.61 m)	(6.09 m)	(4.57 m)
		Max. Length	26 Ft.	21 Ft.	112 Ft.
	(7.92 m)	(6.40 m)	(34.14 m)	(28.04 m)	
Note: Refer to IOM and vent pipe manufacturer's instructions for equivalent vent lengths and alternate venting materials.					
Connections	Return/Supply Water	Gas In	Condensate Drain		
Dimensions	050/075/100	1-1/4" NPT	1/2" NPT	1/2" CPVC Stub	
Width	17-3/4" (451 mm)		Electrical		
Height	36-1/4" (921 mm)		120 Volts AC, 60 hertz, 1 phase, Less than 12 amps (15 amp circuit recommended)		
Depth	17-3/8" (441 mm)		Water Content		
			050/075/100 - 2.6 Gallons		

UB90-100 SERIES IV CONTINUED								
(NATURAL GAS - LESS SYSTEM PUMP)								
BOILER MODEL	ITEM NUMBER	TRADE PRICE	INPUT (MBH)	HTG. CAP. (MBH)	AHRI NET (MBH)	AFUE RATING %	FLUE DIA.	SHIP WGT.
UB90-50	U90205003200410	\$3,352	50	45	39	90	2" or 3"	256
UB90-75	U90207503200410	\$3,352	75	68	59	90	2" or 3"	256
UB90-100	U90210003200410	\$3,352	100	90	78	90	2" or 3"	256
(NATURAL GAS - WITH TACO SYSTEM PUMP)								
BOILER MODEL	ITEM NUMBER	TRADE PRICE	INPUT (MBH)	HTG. CAP. (MBH)	AHRI NET (MBH)	AFUE RATING %	FLUE DIA.	SHIP WGT.
UB90-50	U90205003210410	\$3,422	50	45	39	90	2" or 3"	256
UB90-75	U90207503210410	\$3,422	75	68	59	90	2" or 3"	256
UB90-100	U90210003210410	\$3,422	100	90	78	90	2" or 3"	256
(NATURAL GAS - WITH GRUNDFOS SYSTEM PUMP)								
BOILER MODEL	ITEM NUMBER	TRADE PRICE	INPUT (MBH)	HTG. CAP. (MBH)	AHRI NET (MBH)	AFUE RATING %	FLUE DIA.	SHIP WGT.
UB90-50	U90205003220410	\$3,422	50	45	39	90	2" or 3"	256
UB90-75	U90207503220410	\$3,422	75	68	59	90	2" or 3"	256
UB90-100	U90210003220410	\$3,422	100	90	78	90	2" or 3"	256
(LP GAS - LESS SYSTEM PUMP)								
BOILER MODEL	ITEM NUMBER	TRADE PRICE	INPUT (MBH)	HTG. CAP. (MBH)	AHRI NET (MBH)	AFUE RATING %	FLUE DIA.	SHIP WGT.
UB90-50	U90205013200410	\$3,352	50	45	39	90	2" or 3"	256
UB90-75	U90207513200410	\$3,352	75	68	59	90	2" or 3"	256
UB90-100	U90210013200410	\$3,352	100	90	78	90	2" or 3"	256
(LP GAS - WITH TACO SYSTEM PUMP)								
BOILER MODEL	ITEM NUMBER	TRADE PRICE	INPUT (MBH)	HTG. CAP. (MBH)	AHRI NET (MBH)	AFUE RATING %	FLUE DIA.	SHIP WGT.
UB90-50	U90205013210410	\$3,422	50	45	39	90	2" or 3"	256
UB90-75	U90207513210410	\$3,422	75	68	59	90	2" or 3"	256
UB90-100	U90210013210410	\$3,422	100	90	78	90	2" or 3"	256
(LP GAS - WITH GRUNDFOS SYSTEM PUMP)								
BOILER MODEL	ITEM NUMBER	TRADE PRICE	INPUT (MBH)	HTG. CAP. (MBH)	AHRI NET (MBH)	AFUE RATING %	FLUE DIA.	SHIP WGT.
UB90-50	U90205013220410	\$3,422	50	45	39	90	2" or 3"	256
UB90-75	U90207513220410	\$3,422	75	68	59	90	2" or 3"	256
UB90-100	U90210013220410	\$3,422	100	90	78	90	2" or 3"	256

UB90-100 SERIES IV CONTINUED		
(USE PARTS MULTIPLIER FOR ALL OF THE FOLLOWING)	PN	TRADE
CONCENTRIC VENT KIT 3"	29571	\$218
CONCENTRIC VENT KIT 2"	29570	\$218
ARGO AMB MULTIPLE BOILER CONTROL (INCLUDES OUTDOOR RESET, PRIORITY OVERRIDE, LEAD BOILER RUN TIME ROTATION):		
AMB4A TO ALLOW STAGE FIRING OF UP TO 4 BOILERS	AMB4AU	\$1,000
AMB8A TO ALLOW STAGE FIRING OF UP TO 8 BOILERS	AMB8AU	\$1,275
CONVERSION KIT NAT. TO LP UB90-50 (Series IV) 0' - 10,000'	550002631	\$75
CONVERSION KIT NAT. TO LP UB90-75 (Series IV) 5,000' - 10,000'	550002629	\$75
CONVERSION KIT NAT. TO LP UB90-75 (Series IV) 0' - 5,000'	550002630	\$75
CONVERSION KIT NAT. TO LP UB90-100 (Series IV) 0' - 10,000'	550002700	\$75
CONVERSION KIT LP TO NAT. UB90-50 (Series IV) 0' - 10,000'	550002635	\$75
CONVERSION KIT LP TO NAT. UB90-75 (Series IV) 0' - 10,000'	550002634	\$75
CONVERSION KIT LP TO NAT. UB90-100 (Series IV) 0' - 10,000'	550002701	\$75
2" CPVC 45° ELBOW	14631702	\$37
2" CPVC 90° ELBOW	240009663	\$26
2" CPVC TEE, SCHEDULE 80	240006819	\$36
2" CPVC COUPLING	240006822	\$23
FILL-TROL #110 FOR WATER BOILERS 150 MBH OR LESS	14624002	\$291
FILL-TROL #111 FOR WATER BOILERS OVER 150 MBH	14624003	\$392

**UB90-100 SERIES IV - STANDARD EQUIPMENT**

**STANDARD EQUIPMENT:**

- Boiler Control Module: HSI Integrated Boiler Control
- Combination Hydrolevel High Limit with LWCO with boiler water temperature reset feature
- Heat Exchanger: Cast Aluminum Heat Exchanger
- Combustion: Stainless Steel Premix Burner
- Induced Draft Blower with adjustable exhaust (front, right side or rear), Inducer Motor Assembly, includes 5' schedule 80 2" CPVC and CPVC Tee.
- Electrical: Junction Box, Transformer.
- Textured painted steel jacket.
- Other: Temperature/Pressure Gauge, 30 PSI Safety Relief Valve, Pressure Switch(es), Low Profile

**CUB SERIES**

NATURAL OR PROPANE (WITH CONVERSION KIT)

MODULATING 3:1

SPACE HEATING ONLY BOILER & COMBI UNIT WITH DHW  
(CHIMNEY/SIDEWALL VENTED)



43.5 psi MAWP

**DWB Combi Unit  
(CCB-150) Shown**

See IOM for dimensions  
on other models.

TOP

Width 17-23/32"

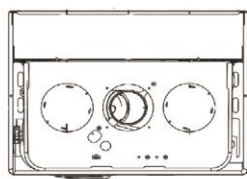

FRONT

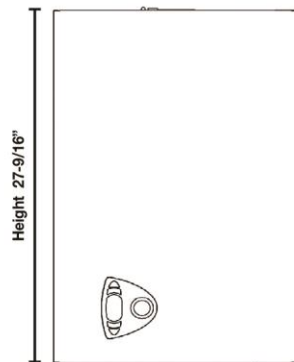

SIDE

Depth 13"



**General Information** (See IOM for complete instructions)

Clearances		Combustible Materials Required <sup>(1)</sup>	Service <sup>(1) (2)</sup>
	Top	16" (41 cm)	16" (41 cm)
	Left Side	0" (0 cm)	1" (3 cm)
	Right Side	0" (0 cm)	1" (3 cm)
	Front	0" (0 cm)	1" (3 cm)
	Back	0" (0 cm)	0" (0 cm)
	Bottom	0" (0 cm)	12" (30 cm)
	Combustion Air/Vent Piping	0" (0 cm)	3/8" (1 cm)
	Vent Piping	6" (15 cm)	6" (15 cm)

**Connections**

CCB-150	Return/Supply Water 1", Gas In 3/4" NPT, Domestic Hot Water Inlet/Outlet 3/4" NPT
CHB-100, CHB-130 & CHB-150	Return/Supply Water 1", Gas In 3/4" NPT, Indirect Tank 3/4" NPT
<b>Electrical</b>	120 Volts AC, 60 hertz, 1 phase, Less than 12 amps (15 amp circuit recommended)
<b>Water Content</b>	CCB-150/CHB-150 - .396 Gallons, CHB-130 - .317 Gallons, CHB-100 - .211 Gallons

**Dimensions**

Model	"Width"	"Height"	"Depth"
CCB-150/CHB-150	17-23/32"	27-9/16"	13"
CHB-130	15-3/4"	27-9/16"	13"
CHB-100	15-3/4"	27-9/16"	13"

CUB SERIES CONTINUED									
(NATURAL GAS - LESS SYSTEM PUMP, COMBI WITH DOMESTIC HOT WATER)									
BOILER MODEL	ITEM NUMBER	TRADE PRICE	INPUT RATE (MBH)	HTG. CAP. (MBH)	AHRI NET (MBH)	AFUE RATING %	CHIMNEY CAT. I (Min. Size)	SIDE-WALL CAT. III	SHIP WGT.
CCB150	CCB0150000110	\$2,280	150	127	110	85.0	4"	3"	78
(NATURAL GAS - LESS SYSTEM PUMP, SPACE HEATING ONLY)									
BOILER MODEL	ITEM NUMBER	TRADE PRICE	INPUT RATE (MBH)	HTG. CAP. (MBH)	AHRI NET (MBH)	AFUE RATING %	CHIMNEY CAT. I (Min. Size)	SIDE-WALL CAT. III	SHIP WGT.
CHB100	CHB0100000110	\$1,766	100	85	73	85.0	4"	3"	65
CHB130	CHB0130000110	\$1,957	130	110	96	85.0	4"	3"	69
CHB150	CHB0150000110	\$2,070	150	130	110	85.0	4"	3"	73
(USE PARTS MULTIPLIER FOR ALL OF THE FOLLOWING)						PN	TRADE		
NATURAL TO LP CONVERSION KIT (CCB150 & CHB-150)						FE3980C150	\$20		
NATURAL TO LP CONVERSION KIT (CHB100)						FE3980C300	\$14		
NATURAL TO LP CONVERSION KIT (CHB130)						FE3980B950	\$18		
DIRECT VENT KIT						5612601	\$142		
OUTSIDE AIR SENSOR						FE013018X0	\$26		
DHW SENSOR KIT						550002958	\$53		
FLOOR STAND KIT						240010266	\$587		

**CUB SERIES - STANDARD EQUIPMENT**

**STANDARD EQUIPMENT:**

- Boiler Control Module: High Limit/Electronic Ignition Control.
- User Display Interface: Digital Temperature Display with diagnostics and programmable settings.
- Heat Exchanger: Copper Fin Tube.  
(CCB-150 combination boiler includes a stainless steel brazed plate heat exchanger - 3.6 gpm at 70°F Temperature Rise, 6.3 gpm at 40°F Temperature Rise)
- Valve: 3-Way Water Diverting Valve.
- Combustion: Completely Installed and Wired Modulating Gas Control System (100% to 33%) with Stainless Steel Burners and Manifold consisting of: Automatic Modulating Gas Valve, Direct Spark Ignition Control, 100% Shut Off, Combination Spark Electrode/Flame Sensor.
- Safety: Pressure Switch (vent safety shutoff).
- Other: Assembled Boiler with Jacket, Induced Draft Fan, Combination Temperature/ Pressure Gauge, Circulator Pump, Gas Shut Off Valve and Field installed - 30lb. ASME Relief Valve.

**SVB SERIES II**

NATURAL OR PROPANE  
HOT WATER BOILER  
INDUCED DRAFT  
(CHIMNEY/SIDEWALL VENTED)



Tested for 50 psi. ASME  
Working Pressure

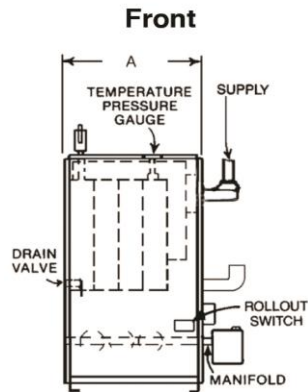

**Left Side**

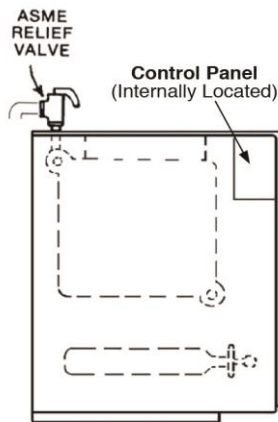

**Right Side**

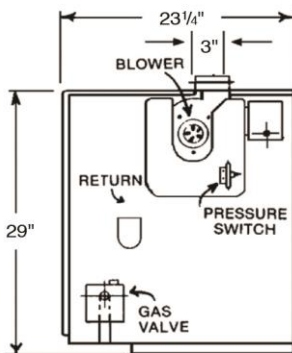

**General Information** (See IOM for complete instructions)

Clearances		Combustible Materials (Required) (1)
		(1) Required distances measured from boiler.
	Top	6" (152 mm)
	Rear	6" (152 mm)
	Right Side	8" (203 mm)
	Opposite Side	6" (152 mm)
	Front (Alcove)*	18" (457 mm)
	Flue Connector	6" (152 mm)

\*Definition of Alcove is three sided space with no wall in front of boiler. ANSI standard for alcove is 18 inches from front of appliance to leading edge of side walls as shown in IOM.

Connections	Return/Supply Water	Gas In
All Models	1-1/4" NPT	1/2" NPT

**Electrical** 120 Volts AC, 60 hertz, 1 phase, Less than 12 amps (15 amp circuit recommended)

**Water Content** SVB-2 - 1.75 Gallons, SVB-3 - 3.00 Gallons, SVB-4 - 4.25 Gallons, SVB-5 - 5.50 Gallons, SVB-6 - 6.75 Gallons, SVB-7 - 8.00 Gallons

Dimensions			
Model	A "Width"	B "Height"	C "Depth"
SVB-2	11"	29"	23-1/4"
SVB-3	14-1/4"	29"	23-1/4"
SVB-4	17-1/2"	29"	23-1/4"
SVB-5	20-3/4"	29"	23-1/4"
SVB-6	24"	29"	23-1/4"
SVB-7	27-1/4"	29"	23-1/4"



SVB SERIES II CONTINUED									
(NATURAL GAS - LESS SYSTEM PUMP)									
BOILER MODEL	ITEM NUMBER	TRADE PRICE	INPUT (MBH)	HTG. CAP. (MBH)	AHRI NET (MBH)	AFUE RATING %	CHIMNEY CAT. I Min. Size	SIDE-WALL CAT. III	SHIP WGT.
SVB-2	SVB204203100210	\$2,156	42.5	36	31	84.4	4"	3"	225
SVB-3	SVB307503100210	\$2,440	75.0	63	55	83.4	4"	3"	265
SVB-4	SVB411203100210	\$2,696	112.5	94	82	83.0	4"	3"	322
SVB-5	SVB515003100210	\$3,030	150.0	125	109	82.7	4"	3"	370
SVB-6	SVB618703100210	\$3,563	187.5	155	135	82.3	4"	4"	431
SVB-7	SVB722503100210	\$3,912	225.0	186	162	82.0	4"	4"	480
(NATURAL GAS - WITH TACO SYSTEM PUMP)									
BOILER MODEL	ITEM NUMBER	TRADE PRICE	INPUT (MBH)	HTG. CAP. (MBH)	AHRI NET (MBH)	AFUE RATING %	CHIMNEY CAT. I Min. Size	SIDE-WALL CAT. III	SHIP WGT.
SVB-2	SVB204203110210	\$2,232	42.5	36	31	84.4	4"	3"	225
SVB-3	SVB307503110210	\$2,515	75.0	63	55	83.4	4"	3"	265
SVB-4	SVB411203110210	\$2,771	112.5	94	82	83.0	4"	3"	322
SVB-5	SVB515003110210	\$3,106	150.0	125	109	82.7	4"	3"	370
SVB-6	SVB618703110210	\$3,638	187.5	155	135	82.3	4"	4"	431
SVB-7	SVB722503110210	\$3,987	225.0	186	162	82.0	4"	4"	480
(NATURAL GAS, HIGH ALTITUDE - WITH TACO SYSTEM PUMP)									
BOILER MODEL	ITEM NUMBER	TRADE PRICE	INPUT (MBH)	HTG. CAP. (MBH)	AHRI NET (MBH)	AFUE RATING %	CHIMNEY CAT. I Min. Size	SIDE-WALL CAT. III	SHIP WGT.
SVB-2	SVB204203112210	\$2,232	42.5	36	31	84.4	4"	3"	225
SVB-3	SVB307503112210	\$2,515	75.0	63	55	83.4	4"	3"	265
SVB-4	SVB411203112210	\$2,771	112.5	94	82	83.0	4"	3"	322
SVB-5	SVB515003112210	\$3,106	150.0	125	109	82.7	4"	3"	370
SVB-6	SVB618703112210	\$3,638	187.5	155	135	82.3	4"	4"	431
SVB-7	SVB722503112210	\$3,987	225.0	186	162	82.0	4"	4"	480
(NATURAL GAS - WITH GRUNDFOS SYSTEM PUMP)									
BOILER MODEL	ITEM NUMBER	TRADE PRICE	INPUT (MBH)	HTG. CAP. (MBH)	AHRI NET (MBH)	AFUE RATING %	CHIMNEY CAT. I Min. Size	SIDE-WALL CAT. III	SHIP WGT.
SVB-2	SVB204203120210	\$2,232	42.5	36	31	84.4	4"	3"	225
SVB-3	SVB307503120210	\$2,515	75.0	63	55	83.4	4"	3"	265
SVB-4	SVB411203120210	\$2,771	112.5	94	82	83.0	4"	3"	322
SVB-5	SVB515003120210	\$3,106	150.0	125	109	82.7	4"	3"	370
SVB-6	SVB618703120210	\$3,638	187.5	155	135	82.3	4"	4"	431
SVB-7	SVB722503120210	\$3,987	225.0	186	162	82.0	4"	4"	480
(NATURAL GAS, HIGH ALTITUDE - WITH GRUNDFOS SYSTEM PUMP)									
BOILER MODEL	ITEM NUMBER	TRADE PRICE	INPUT (MBH)	HTG. CAP. (MBH)	AHRI NET (MBH)	AFUE RATING %	CHIMNEY CAT. I Min. Size	SIDE-WALL CAT. III	SHIP WGT.
SVB-2	SVB204203122210	\$2,232	42.5	36	31	84.4	4"	3"	225
SVB-3	SVB307503122210	\$2,515	75.0	63	55	83.4	4"	3"	265
SVB-4	SVB411203122210	\$2,771	112.5	94	82	83.0	4"	3"	322
SVB-5	SVB515003122210	\$3,106	150.0	125	109	82.7	4"	3"	370
SVB-6	SVB618703122210	\$3,638	187.5	155	135	82.3	4"	4"	431
SVB-7	SVB722503122210	\$3,987	225.0	186	162	82.0	4"	4"	480

SVB SERIES II CONTINUED									
(NATURAL GAS - WITH B & G SYSTEM PUMP)									
BOILER MODEL	ITEM NUMBER	TRADE PRICE	INPUT (MBH)	HTG. CAP. (MBH)	AHRI NET (MBH)	AFUE RATING %	CHIMNEY CAT. I Min. Size	SIDE-WALL CAT. III	SHIP WGT.
SVB-2	SVB204203130210	\$2,232	42.5	36	31	84.4	4"	3"	225
SVB-3	SVB307503130210	\$2,515	75.0	63	55	83.4	4"	3"	265
SVB-4	SVB411203130210	\$2,771	112.5	94	82	83.0	4"	3"	322
SVB-5	SVB515003130210	\$3,106	150.0	125	109	82.7	4"	3"	370
SVB-6	SVB618703130210	\$3,638	187.5	155	135	82.3	4"	4"	431
SVB-7	SVB722503130210	\$3,987	225.0	186	162	82.0	4"	4"	480
(LP GAS - LESS SYSTEM PUMP)									
BOILER MODEL	ITEM NUMBER	TRADE PRICE	INPUT (MBH)	HTG. CAP. (MBH)	AHRI NET (MBH)	AFUE RATING %	CHIMNEY CAT. I Min. Size	SIDE-WALL CAT. III	SHIP WGT.
SVB-2	SVB204213100210	\$2,208	42.5	36	31	84.4	4"	3"	225
SVB-3	SVB307513100210	\$2,492	75.0	63	55	83.4	4"	3"	265
SVB-4	SVB411213100210	\$2,748	112.5	94	82	83.0	4"	3"	322
SVB-5	SVB515013100210	\$3,082	150.0	125	109	82.7	4"	3"	370
SVB-6	SVB618713100210	\$3,615	187.5	155	135	82.3	4"	4"	431
SVB-7	SVB722513100210	\$3,964	225.0	186	162	82.0	4"	4"	480
(LP GAS - WITH TACO SYSTEM PUMP)									
BOILER MODEL	ITEM NUMBER	TRADE PRICE	INPUT (MBH)	HTG. CAP. (MBH)	AHRI NET (MBH)	AFUE RATING %	CHIMNEY CAT. I Min. Size	SIDE-WALL CAT. III	SHIP WGT.
SVB-2	SVB204213110210	\$2,284	42.5	36	31	84.4	4"	3"	225
SVB-3	SVB307513110210	\$2,567	75.0	63	55	83.4	4"	3"	265
SVB-4	SVB411213110210	\$2,824	112.5	94	82	83.0	4"	3"	322
SVB-5	SVB515013110210	\$3,158	150.0	125	109	82.7	4"	3"	370
SVB-6	SVB618713110210	\$3,690	187.5	155	135	82.3	4"	4"	431
SVB-7	SVB722513110210	\$4,039	225.0	186	162	82.0	4"	4"	480
(LP GAS - WITH GRUNDFOS SYSTEM PUMP)									
BOILER MODEL	ITEM NUMBER	TRADE PRICE	INPUT (MBH)	HTG. CAP. (MBH)	AHRI NET (MBH)	AFUE RATING %	CHIMNEY CAT. I Min. Size	SIDE-WALL CAT. III	SHIP WGT.
SVB-2	SVB204213120210	\$2,284	42.5	36	31	84.4	4"	3"	225
SVB-3	SVB307513120210	\$2,567	75.0	63	55	83.4	4"	3"	265
SVB-4	SVB411213120210	\$2,824	112.5	94	82	83.0	4"	3"	322
SVB-5	SVB515013120210	\$3,158	150.0	125	109	82.7	4"	3"	370
SVB-6	SVB618713120210	\$3,690	187.5	155	135	82.3	4"	4"	431
SVB-7	SVB722513120210	\$4,039	225.0	186	162	82.0	4"	4"	480
(LP GAS - WITH B & G SYSTEM PUMP)									
BOILER MODEL	ITEM NUMBER	TRADE PRICE	INPUT (MBH)	HTG. CAP. (MBH)	AHRI NET (MBH)	AFUE RATING %	CHIMNEY CAT. I Min. Size	SIDE-WALL CAT. III	SHIP WGT.
SVB-2	SVB204213130210	\$2,284	42.5	36	31	84.4	4"	3"	225
SVB-3	SVB307513130210	\$2,567	75.0	63	55	83.4	4"	3"	265
SVB-4	SVB411213130210	\$2,824	112.5	94	82	83.0	4"	3"	322
SVB-5	SVB515013130210	\$3,158	150.0	125	109	82.7	4"	3"	370
SVB-6	SVB618713130210	\$3,690	187.5	155	135	82.3	4"	4"	431
SVB-7	SVB722513130210	\$4,039	225.0	186	162	82.0	4"	4"	480

SVB SERIES II CONTINUED		
(USE PARTS MULTIPLIER FOR ALL OF THE FOLLOWING)	PN	TRADE
NATURAL TO LP CONVERSION KIT (ALL SIZES)	550002722	\$82
LP TO NATURAL CONVERSION KIT (ALL SIZES)	43300660	\$90
COMBUSTIBLE FLOOR PLATE FOR ALL CAPACITIES	14614032	\$96
4" THIMBLE (SIMPSON #915295)	14629014	\$40
TJERNLUND VH-1-3" SIDE WALL VENT HOOD (SVB-2 TO SVB-5)	14629010	\$229
TJERNLUND VH-1-4" SIDE WALL VENT HOOD (SVB-6 & SVB-7))	14629011	\$274
FILL-TROL #110 FOR WATER BOILERS 150 MBH OR LESS	14624002	\$291
FILL-TROL #111 FOR WATER BOILERS OVER 150 MBH	14624003	\$392

**SVB (Series II) - STANDARD EQUIPMENT**

**STANDARD EQUIPMENT:**

- Boiler Control Module: Recessed Honeywell Control (High Limit/Electronic Ignition Control).
- User Display Interface: Digital Temperature Display.
- Heat Exchanger: Cast Iron Sections with Cast Iron Push Nipples.
- Combustion: Completely Installed and Wired Gas Control System with Titanium Composite Burners and Manifold consisting of: Automatic Redundant Combination Gas Valve, 24 Volt Intermittent Pilot Control, Continuous Retry 100% Shut Off, Combination Pilot Burner/Electrode/Flame Sensor.
- Electrical: 24 Volt Transformer, Service Switch.
- Safety: Flame Roll-Out Safety Shut-Off (Fuse Link) and Pressure Switch (vent safety shutoff) with Spare Fuse Link included.
- Other: Assembled Boiler with Insulated Jacket, Induced Draft Fan, Combination Temperature/Pressure Gauge, Circulator Pump, 3/4" Drain Valve, 30lb. ASME Relief Valve.

**MGB SERIES II & MGC SERIES**

NATURAL OR PROPANE  
HOT WATER BOILER  
CHIMNEY VENTED  
(PROTECTED CONTROLS)



Tested for 100 psi (MGB) / 50 psi (MGC)  
ASME Working Pressure

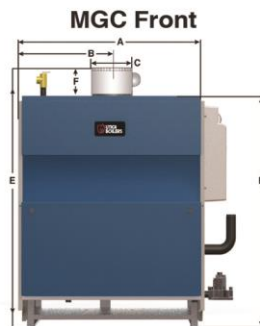
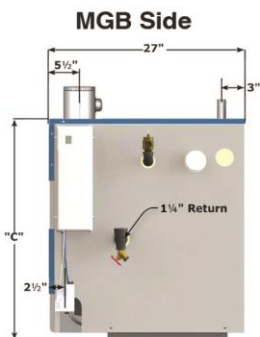
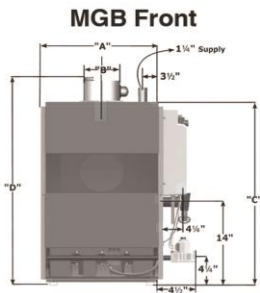

**General Information** (See IOM for complete instructions)

Clearances		Combustible Materials (Required) (1)	
		MGB II	MGC
(1) Required distances measured from boiler.	Top	18" (457 mm)	6" (152 mm)
	Front	Alcove*	18" (457 mm)
	Flue Connector	6" (152 mm)	6" (152 mm)
	Rear	4" (102 mm)	6" (152 mm)
	Control Side	9" (229 mm)	7" (178 mm)
	Other Side	3" (76 mm)	6" (152 mm)

\*Definition of Alcove is three sided space with no wall in front of boiler. ANSI standard for alcove is 18 inches from front of appliance to leading edge of side walls as shown in IOM.

Connections	Return/Supply Water	Gas In
All Models	1-1/4" NPT	1/2" NPT
Electrical	120 Volts AC, 60 hertz, 1 phase, Less than 12 amps (15 amp circuit recommended)	
Water Content	50 - 2.4 Gallons, 75/100 - 4.0 Gallons, 125/150 - 5.6 Gallons, 170/200 - 7.2 Gallons, 262.5 - 12.7 Gallons, 299 - 14.4 Gallons	

Dimensions				
Model	A	B	C	D
MGB-50J	11-1/8"	4"	30-3/4"	36-1/4"
MGB-75J	15"	5"	30-3/4"	37-3/4"
MGB-100J	15"	6"	30-3/4"	37-1/4"
MGB-125J	18-7/8"	6"	30-3/4"	37-1/4"
MGB-150J	18-7/8"	7"	30-3/4"	37-3/4"
MGB-170J	22-3/4"	7"	30-3/4"	38-3/4"
MGB-200J	22-3/4"	8"	30-3/4"	38-3/4"
Model	A	C	D	E
MGC-8D/DP	27-1/2"	7"	36-3/8"	41-7/8"
MGC-9D/DP	30-3/4"	7"	36-3/8"	41-7/8"

MGB SERIES II & MGC SERIES CONTINUED									
(NATURAL GAS - LESS SYSTEM PUMP)									
BOILER MODEL	ITEM NUMBER	TRADE PRICE	INPUT (MBH)	HTG. CAP. (MBH)	AHRI NET (MBH)	AFUE RATING %	AIR CUSHION TANK	NO. OF BRNS.	SHIP WGT.
MGB-50J	MGB205003100210	\$1,989	50	52	37	83.5	15	1	205
MGB-75J	MGB307503100210	\$2,241	75	63	55	83.1	15	2	253
MGB-100J	MGB310003100210	\$2,321	100	83	72	83.0	30	2	253
MGB-125J	MGB412503100210	\$2,542	125	104	90	82.0	30	3	315
MGB-150J	MGB415003100210	\$2,625	150	124	108	83.0	30	3	315
MGB-170J	MGB517003100210	\$3,118	170	139	121	82.0	30	4	377
MGB-200J	MGB520003100210	\$3,298	200	165	143	82.0	30	4	377
MGC-8D	MGC826203100210	\$3,910	262.5	220	191	83.9	60	7	552
MGC-9D	MGC929903100210	\$4,504	299	251	218	83.7	60	8	616
(NATURAL GAS - WITH TACO SYSTEM PUMP)									
BOILER MODEL	ITEM NUMBER	TRADE PRICE	INPUT (MBH)	HTG. CAP. (MBH)	AHRI NET (MBH)	AFUE RATING %	AIR CUSHION TANK	NO. OF BRNS.	SHIP WGT.
MGB-50J	MGB205003110210	\$2,064	50	52	37	83.5	15	1	205
MGB-75J	MGB307503110210	\$2,316	75	63	55	83.1	15	2	253
MGB-100J	MGB310003110210	\$2,395	100	83	72	83.0	30	2	253
MGB-125J	MGB412503110210	\$2,616	125	104	90	82.0	30	3	315
MGB-150J	MGB415003110210	\$2,701	150	124	108	83.0	30	3	315
MGB-170J	MGB517003110210	\$3,193	170	139	121	82.0	30	4	377
MGB-200J	MGB520003110210	\$3,373	200	165	143	82.0	30	4	377
MGC-8D	MGC826203110210	\$3,985	262.5	220	191.0	83.9	60	7	552
MGC-9D	MGC929903110210	\$4,580	299	251	218.0	83.7	60	8	616
(NATURAL GAS, HIGH ALTITUDE - WITH TACO SYSTEM PUMP)									
BOILER MODEL	ITEM NUMBER	TRADE PRICE	INPUT (MBH)	HTG. CAP. (MBH)	AHRI NET (MBH)	AFUE RATING %	AIR CUSHION TANK	NO. OF BRNS.	SHIP WGT.
MGB-50J	MGB205003112210	\$2,064	50	52	37	83.5	15	1	205
MGB-75J	MGB307503112210	\$2,316	75	63	55	83.1	15	2	253
MGB-100J	MGB310003112210	\$2,395	100	83	72	83.0	30	2	253
MGB-125J	MGB412503112210	\$2,616	125	104	90	82.0	30	3	315
MGB-150J	MGB415003112210	\$2,701	150	124	108	83.0	30	3	315
MGB-170J	MGB517003112210	\$3,193	170	139	121	82.0	30	4	377
MGB-200J	MGB520003112210	\$3,373	200	165	143	82.0	30	4	377
MGC-8D	MGC826203112210	\$3,985	262.5	220	191.0	83.9	60	7	552
MGC-9D	MGC929903112210	\$4,580	299	251	218.0	83.7	60	8	616
(NATURAL GAS - WITH GRUNDFOS SYSTEM PUMP)									
BOILER MODEL	ITEM NUMBER	TRADE PRICE	INPUT (MBH)	HTG. CAP. (MBH)	AHRI NET (MBH)	AFUE RATING %	AIR CUSHION TANK	NO. OF BRNS.	SHIP WGT.
MGB-50J	MGB205003120210	\$2,064	50	52	37	83.5	15	1	205
MGB-75J	MGB307503120210	\$2,316	75	63	55	83.1	15	2	253
MGB-100J	MGB310003120210	\$2,395	100	83	72	83.0	30	2	253
MGB-125J	MGB412503120210	\$2,616	125	104	90	82.0	30	3	315
MGB-150J	MGB415003120210	\$2,701	150	124	108	83.0	30	3	315
MGB-170J	MGB517003120210	\$3,193	170	139	121	82.0	30	4	377
MGB-200J	MGB520003120210	\$3,373	200	165	143	82.0	30	4	377
MGC-8D	MGC826203120210	\$3,985	262.5	220	191.0	83.9	60	7	552
MGC-9D	MGC929903120210	\$4,580	299	251	218.0	83.7	60	8	616

MGB SERIES II & MGC SERIES CONTINUED									
(NATURAL GAS, HIGH ALTITUDE - WITH GRUNDFOS SYSTEM PUMP)									
BOILER MODEL	ITEM NUMBER	TRADE PRICE	INPUT (MBH)	HTG. CAP. (MBH)	AHRI NET (MBH)	AFUE RATING %	AIR CUSHION TANK	NO. OF BRNS.	SHIP WGT.
MGB-50J	MGB205003122210	\$2,064	50	52	37	83.5	15	1	205
MGB-75J	MGB307503122210	\$2,316	75	63	55	83.1	15	2	253
MGB-100J	MGB310003122210	\$2,395	100	83	72	83.0	30	2	253
MGB-125J	MGB412503122210	\$2,616	125	104	90	82.0	30	3	315
MGB-150J	MGB415003122210	\$2,701	150	124	108	83.0	30	3	315
MGB-170J	MGB517003122210	\$3,193	170	139	121	82.0	30	4	377
MGB-200J	MGB520003122210	\$3,373	200	165	143	82.0	30	4	377
(NATURAL GAS - WITH B & G SYSTEM PUMP)									
BOILER MODEL	ITEM NUMBER	TRADE PRICE	INPUT (MBH)	HTG. CAP. (MBH)	AHRI NET (MBH)	AFUE RATING %	AIR CUSHION TANK	NO. OF BRNS.	SHIP WGT.
MGB-50J	MGB205003130210	\$2,064	50	52	37	83.5	15	1	205
MGB-75J	MGB307503130210	\$2,316	75	63	55	83.1	15	2	253
MGB-100J	MGB310003130210	\$2,395	100	83	72	83.0	30	2	253
MGB-125J	MGB412503130210	\$2,616	125	104	90	82.0	30	3	315
MGB-150J	MGB415003130210	\$2,701	150	124	108	83.0	30	3	315
MGB-170J	MGB517003130210	\$3,193	170	139	121	82.0	30	4	377
MGB-200J	MGB520003130210	\$3,373	200	165	143	82.0	30	4	377
MGC-8D	MGC826203130210	\$3,985	262.5	220	191.0	83.9	60	7	552
MGC-9D	MGC929903130210	\$4,580	299	251	218.0	83.7	60	8	616
(LP GAS - LESS SYSTEM PUMP)									
BOILER MODEL	ITEM NUMBER	TRADE PRICE	INPUT (MBH)	HTG. CAP. (MBH)	AHRI NET (MBH)	AFUE RATING %	AIR CUSHION TANK	NO. OF BRNS.	SHIP WGT.
MGC-8DP	MGC826213100210	\$3,962	245	206	179	83.9	60	7	552
MGC-9DP	MGC929913100210	\$4,556	280	235	204	83.7	60	8	616
(LP GAS - WITH TACO SYSTEM PUMP)									
BOILER MODEL	ITEM NUMBER	TRADE PRICE	INPUT (MBH)	HTG. CAP. (MBH)	AHRI NET (MBH)	AFUE RATING %	AIR CUSHION TANK	NO. OF BRNS.	SHIP WGT.
MGB-50J	MGB205013110210	\$2,117	50	52	37	83.5	15	1	205
MGB-75J	MGB307513110210	\$2,368	75	63	55	83.1	15	2	253
MGB-100J	MGB310013110210	\$2,447	100	83	72	83.0	30	2	253
MGB-125J	MGB412513110210	\$2,668	125	104	90	82.0	30	3	315
MGB-150J	MGB415013110210	\$2,753	150	124	108	83.0	30	3	315
MGB-170J	MGB517013110210	\$3,245	170	139	121	82.0	30	4	377
MGB-200J	MGB520013110210	\$3,425	200	165	143	82.0	30	4	377
MGC-8DP	MGC826213110210	\$4,037	245	206	179	83.9	60	7	552
MGC-9DP	MGC929913110210	\$4,632	280	235	204	83.7	60	8	616

MGB SERIES II & MGC SERIES CONTINUED									
(LP GAS - WITH GRUNDFOS SYSTEM PUMP)									
BOILER MODEL	ITEM NUMBER	TRADE PRICE	INPUT (MBH)	HTG. CAP. (MBH)	AHRI NET (MBH)	AFUE RATING %	AIR CUSHION TANK	NO. OF BRNS.	SHIP WGT.
MGB-50J	MGB205013120210	\$2,117	50	52	37	83.5	15	1	205
MGB-75J	MGB307513120210	\$2,368	75	63	55	83.1	15	2	253
MGB-100J	MGB310013120210	\$2,447	100	83	72	83.0	30	2	253
MGB-125J	MGB412513120210	\$2,668	125	104	90	82.0	30	3	315
MGB-150J	MGB415013120210	\$2,753	150	124	108	83.0	30	3	315
MGB-170J	MGB517013120210	\$3,245	170	139	121	82.0	30	4	377
MGB-200J	MGB520013120210	\$3,425	200	165	143	82.0	30	4	377
MGC-8DP	MGC826213120210	\$4,037	245	206	179	83.9	60	7	552
MGC-9DP	MGC929913120210	\$4,632	280	235	204	83.7	60	8	616
(LP GAS - WITH B & G SYSTEM PUMP)									
BOILER MODEL	ITEM NUMBER	TRADE PRICE	INPUT (MBH)	HTG. CAP. (MBH)	AHRI NET (MBH)	AFUE RATING %	AIR CUSHION TANK	NO. OF BRNS.	SHIP WGT.
MGB-50J	MGB205013130210	\$2,117	50	52	37	83.5	15	1	205
MGB-75J	MGB307513130210	\$2,368	75	63	55	83.1	15	2	253
MGB-100J	MGB310013130210	\$2,447	100	83	72	83.0	30	2	253
MGB-125J	MGB412513130210	\$2,668	125	104	90	82.0	30	3	315
MGB-150J	MGB415013130210	\$2,753	150	124	108	83.0	30	3	315
MGB-170J	MGB517013130210	\$3,245	170	139	121	82.0	30	4	377
MGB-200J	MGB520013130210	\$3,425	200	165	143	82.0	30	4	377
MGC-8DP	MGC826213130210	\$4,037	245	206	179	83.9	60	7	552
MGC-9DP	MGC929913130210	\$4,632	280	235	204	83.7	60	8	616

MGB SERIES II & MGC SERIES CONTINUED		
(USE PARTS MULTIPLIER FOR ALL OF THE FOLLOWING)	PN	TRADE
COMBUSTIBLE FLOOR PLATE MGB-50J	325-2-8.01	\$212
COMBUSTIBLE FLOOR PLATE MGB-75J	325-2-8.02	\$222
COMBUSTIBLE FLOOR PLATE MGB-100J	325-2-8.02	\$222
COMBUSTIBLE FLOOR PLATE MGB-125J	325-2-8.03	\$244
COMBUSTIBLE FLOOR PLATE MGB-150J	325-2-8.03	\$244
COMBUSTIBLE FLOOR PLATE MGB-170J	325-2-8.04	\$244
COMBUSTIBLE FLOOR PLATE MGB-200J	325-2-8.04	\$244
COMBUSTIBLE FLOOR PLATE MGC-8D,8DP,9D,9DP	14614032	\$96
CONVERSION KIT NAT. TO LP MGB-50J	550002663	\$82
CONVERSION KIT NAT. TO LP MGB-75J	550002664	\$82
CONVERSION KIT NAT. TO LP MGB-100J	550002663	\$82
CONVERSION KIT NAT. TO LP MGB-125J	550002665	\$82
CONVERSION KIT NAT. TO LP MGB-150J	550002663	\$82
CONVERSION KIT NAT. TO LP MGB-170J	550002665	\$82
CONVERSION KIT NAT. TO LP MGB-200J	550002663	\$82
CONVERSION KIT NAT. TO LP MGC-8	43300728	\$59
CONVERSION KIT NAT. TO LP MGC-9	43300729	\$59
CONVERSION KIT LP TO NAT. MGB-50J	5611902	\$100
CONVERSION KIT LP TO NAT. MGB-75J	5611903	\$102
CONVERSION KIT LP TO NAT. MGB-100J	5611904	\$102
CONVERSION KIT LP TO NAT. MGB-125J	5611905	\$104
CONVERSION KIT LP TO NAT. MGB-150J	5611906	\$104
CONVERSION KIT LP TO NAT. MGB-170J	5611905	\$104
CONVERSION KIT LP TO NAT. MGB-200J	5611908	\$106
CONVERSION KIT LP TO NAT. MGC-8	43300636	\$130
CONVERSION KIT LP TO NAT. MGC-9	43300637	\$155
FILL-TROL #110 FOR WATER BOILERS 150 MBH OR LESS	14624002	\$291
FILL-TROL #111 FOR WATER BOILERS OVER 150 MBH	14624003	\$392

**MGB SERIES II & MGC SERIES STANDARD EQUIPMENT**

**STANDARD EQUIPMENT:**

- Boiler Control Module: Honeywell Control (High Limit/Electronic Ignition Control) with plastic cover and display window.
- User Display Interface: Digital Temperature Display
- Heat Exchanger: Cast Iron Sections with Cast Iron Push Nipples.
- Combustion: Stainless Steel Main Gas Burners (MGB)/Titanium Composite Burners (MGC), Combination 24 Volt Gas Control (Includes: Automatic Gas Valve, Gas Pressure Regulator, Automatic Pilot, Safety Shutoff, Pilot Flow Adjustment, Pilot Filter), Intermittent Pilot Control, Continuous Retry, Combination Pilot Burner/Electrode/Flame Sensor.
- Safety: Spill Switch and Roll-Out Switch for safety (MGB)/Flame Roll-Out Safety Shut-Off (Fuse Link) (MGC), Automatic Vent Damper.
- Other: Insulated Boiler Jacket, Integral Draft Diverter, Combination Temperature/Pressure Gauge, Circulator Pump, 3/4" Drain Valve, 30lb. ASME Relief Valve.



**PEG-E SERIES**  
 NATURAL OR PROPANE  
 STEAM BOILER

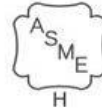

15 psi  
 MAWP



**Front**

**Left Side**

**Right Side**

**Back**

General Information (See IOM for complete instructions)			
<b>Clearances</b>		<b>Combustible Materials (Required) (1)</b>	
(1) Required distances measured from boiler.	<b>Top</b>	6" (152 mm)	
	<b>Left Side (Control Side)</b>	7" (178 mm)	
	<b>Right Side</b>	6" (152 mm)	
	<b>Front</b>	Alcove*	
	<b>Back</b>	6" (152 mm)	
	<b>Flue Connector</b>	6" (152 mm)	
*Definition of Alcove is three sided space with no wall in front of boiler. ANSI standard for alcove is 18 inches from front of appliance to leading edge of side walls as shown in IOM.			
<b>Connections</b>	<b>Supply</b>	<b>Return</b>	
	Two 2"	Two 2"	
<b>Electrical</b>	120 Volts AC, 60 hertz, 1 phase, Less than 12 amps (15 amp circuit recommended)		
<b>Dimensions</b>			
<b>Model</b>	<b>A "Width"</b>	<b>B "Height"</b>	<b>C "Depth"</b>
PEG075EID	10-7/8"	35-7/8"	28-3/8"
PEG112EID	14-1/8"	35-7/8"	28-3/8"
PEG150EID	17-3/8"	35-7/8"	29-3/8"
PEG187EID	20-5/8"	35-7/8"	30-3/8"
PEG225EID	23-7/8"	35-7/8"	30-3/8"
PEG262EID	27-1/8"	35-7/8"	30-3/8"
PEG299EID	30-3/8"	35-7/8"	30-3/8"

PEG-E SERIES CONTINUED									
(NATURAL GAS)									
BOILER MODEL	ITEM NUMBER	TRADE PRICE	INPUT (MBH)	HTG. CAP. (MBH)	AHRI NET (MBH)	AHRI NET SQ. FT. STEAM	AFUE RATING %	FLUE DIA.	SHIP WGT.
PEG075EID	PEG307503100510	\$2,896	75	62	47	195	82.2	5"	297
PEG112EID	PEG411203100510	\$3,198	112	93	70	292	82.4	5"	368
PEG150EID	PEG515003100510	\$3,481	150	125	94	391	82.6	6"	440
PEG187EID	PEG618703100510	\$3,747	187	156	117	488	82.8	7"	512
PEG225EID	PEG722503100510	\$4,400	225	188	141	587	83.0	7"	584
PEG262EID	PEG826203100510	\$4,722	263	219	164	685	83.2	7"	659
PEG299EID	PEG929903100510	\$5,116	299	250	188	782	83.4	7"	736
(LP GAS)									
BOILER MODEL	ITEM NUMBER	TRADE PRICE	INPUT (MBH)	HTG. CAP. (MBH)	AHRI NET (MBH)	AHRI NET SQ. FT. STEAM	AFUE RATING %	FLUE DIA.	SHIP WGT.
PEG075EID	PEG307513100510	\$2,949	75	62	47	195	82.2	5"	297
PEG112EID	PEG411213100510	\$3,252	112	93	70	292	82.4	5"	368
PEG150EID	PEG515013100510	\$3,535	150	125	94	391	82.6	6"	440
PEG187EID	PEG618713100510	\$3,800	187	156	117	488	82.8	7"	512
PEG225EID	PEG722513100510	\$4,454	225	188	141	587	83.0	7"	584
PEG262EID	PEG826213100510	\$4,774	263	219	164	685	83.2	7"	659
PEG299EID	PEG929913100510	\$5,169	299	250	188	782	83.4	7"	736
(USE PARTS MULTIPLIER FOR ALL OF THE FOLLOWING)						PN	TRADE		
CONVERSION KIT NAT. TO LP (3 - 5 SECTION)						550002702	\$56		
CONVERSION KIT NAT. TO LP (6 - 9 SECTION)						550002703	\$59		
CONVERSION KIT LP TO NAT. (3 - 5 SECTION)						550002704	\$62		
CONVERSION KIT LP TO NAT. (6 - 9 SECTION)						550002705	\$82		
MCDONNELL & MILLER WF-2U-24 ELECTRONIC WATER FEEDER						1630001	\$465		
COMBUSTIBLE FLOOR PLATE FOR ALL CAPACITIES						14614032	\$96		
PEG-E SERIES - STANDARD EQUIPMENT									
<b><u>STANDARD EQUIPMENT:</u></b>									
<ul style="list-style-type: none"> <li>- Boiler Controls: LWCO (Probe Type), Pressure High Limit Control, Pressure Gauge, Gauge Glass.</li> <li>- Heat Exchanger: Cast Iron Sections with Cast Iron Push Nipples, (2) - 2" Supply Tappings; (2) - 2" Return Tappings.</li> <li>- Combustion: Stainless Steel Burners, Gas Valve, Intermittent Pilot Control with Continuous Retry and Combination Pilot Burner/Electrode Flame Sensor, Integral Draft Hood, Vent Damper.</li> <li>- Electrical: 24 Volt, 24VA Transformer.</li> <li>- Safety: Blocked Vent and Rollout Safety Switches, Pop Safety Valve.</li> <li>- Other: Crated Cast Iron Boiler with Insulated Jacket; Boiler Drain.</li> </ul>									

**JE SERIES**

GAS FIRED

COMMERICAL STEAM BOILER



**JE SERIES STEAM  
(STANDARD MODEL)**

BOILER MODEL	ITEM NUMBER	TRADE PRICE	INPUT BTU (MBH)	THERM. EFF.	OUT-PUT BTU (MBH)	NET AHRI RATINGS			NO. OF SECT.	SHIP WGT.
						STEAM PPF	STEAM SQ. FT.	STEAM BTU (MBH)		
JE300S	CBA030003101110	\$5,869	300	77%	233	1.33	729	175	4	1000
JE400S	CBA040003101110	\$6,603	400	77%	310	1.33	971	233	5	1200
JE500S	CBA050003101110	\$7,341	500	77%	388	1.33	1213	291	6	1400
JE600S	CBA060003101110	\$9,546	600	77%	465	1.33	1454	349	7	1600
JE700S	CBA070003101110	\$10,282	700	77%	543	1.33	1696	407	8	1800
JE800S	CBA080003101110	\$11,047	800	77%	620	1.33	1938	465	9	2000
JE900S	CBA090003101110	\$11,855	900	77%	698	1.33	2183	524	10	2200
JE1000S	CBA100003101110	\$12,590	1000	77%	775	1.33	2421	581	11	2400
JE1100S	CBA110003101110	\$14,854	1100	77%	853	1.33	2667	640	12	2600
JE1200S	CBA120003101110	\$15,589	1200	77%	930	1.33	2908	698	13	2900
JE1300S	CBA130003101110	\$16,753	1300	77%	1008	1.33	3150	756	14	3100
JE1400S	CBA140003101110	\$17,491	1400	77%	1085	1.33	3392	814	15	3300
JE1500S	CBA150003101110	\$18,244	1500	77%	1163	1.33	3633	872	16	3500

**(CSD-1 GRAVITY RETURN SYSTEM)**

BOILER MODEL	ITEM NUMBER	TRADE PRICE	INPUT BTU (MBH)	THERM. EFF.	OUT-PUT BTU (MBH)	NET AHRI RATINGS			NO. OF SECT.	SHIP WGT.
						STEAM PPF	STEAM SQ. FT.	STEAM BTU (MBH)		
JE300S	CBA030003103110	\$6,552	300	77%	233	1.33	729	175	4	1000
JE400S	CBA040003103110	\$7,286	400	77%	310	1.33	971	233	5	1200
JE500S	CBA050003103110	\$8,024	500	77%	388	1.33	1213	291	6	1400
JE600S	CBA060003103110	\$11,002	600	77%	465	1.33	1454	349	7	1600
JE700S	CBA070003103110	\$11,753	700	77%	543	1.33	1696	407	8	1800
JE800S	CBA080003103110	\$12,518	800	77%	620	1.33	1938	465	9	2000
JE900S	CBA090003103110	\$13,326	900	77%	698	1.33	2183	524	10	2200
JE1000S	CBA100003103110	\$14,060	1000	77%	775	1.33	2421	581	11	2400
JE1100S	CBA110003103110	\$16,617	1100	77%	853	1.33	2667	640	12	2600
JE1200S	CBA120003103110	\$17,352	1200	77%	930	1.33	2908	698	13	2900
JE1300S	CBA130003103110	\$18,516	1300	77%	1008	1.33	3150	756	14	3100
JE1400S	CBA140003103110	\$19,255	1400	77%	1085	1.33	3392	814	15	3300
JE1500S	CBA150003103110	\$20,008	1500	77%	1163	1.33	3633	872	16	3500

JE SERIES STEAM CONTINUED											
(CSD-1 BOILER FEED PUMP RETURN CONTROL)											
BOILER MODEL	ITEM NUMBER	TRADE PRICE	INPUT BTU (MBH)	THERM. EFF.	OUT-PUT (MBH)	NET AHRI RATINGS			NO. OF SECT.	SHIP WGT.	
						STEAM PPF	STEAM SQ. FT.	STEAM BTU (MBH)			
JE300S	CBA030003104110	\$7,253	300	77%	233	1.33	729	175	4	1000	
JE400S	CBA040003104110	\$7,987	400	77%	310	1.33	971	233	5	1200	
JE500S	CBA050003104110	\$8,725	500	77%	388	1.33	1213	291	6	1400	
JE600S	CBA060003104110	\$11,704	600	77%	465	1.33	1454	349	7	1600	
JE700S	CBA070003104110	\$12,454	700	77%	543	1.33	1696	407	8	1800	
JE800S	CBA080003104110	\$13,218	800	77%	620	1.33	1938	465	9	2000	
JE900S	CBA090003104110	\$14,027	900	77%	698	1.33	2183	524	10	2200	
JE1000S	CBA100003104110	\$14,761	1000	77%	775	1.33	2421	581	11	2400	
JE1100S	CBA110003104110	\$17,318	1100	77%	853	1.33	2667	640	12	2600	
JE1200S	CBA120003104110	\$18,054	1200	77%	930	1.33	2908	698	13	2900	
JE1300S	CBA130003104110	\$19,218	1300	77%	1008	1.33	3150	756	14	3100	
JE1400S	CBA140003104110	\$19,956	1400	77%	1085	1.33	3392	814	15	3300	
JE1500S	CBA150003104110	\$20,709	1500	77%	1163	1.33	3633	872	16	3500	
FOR ORDERING KNOCK DOWN OR ALA CARTE											
JE-COMPONENTS & OPTIONAL EQUIP.											
								PN	TRADE		
CAST IRON SECTIONS - RIGHT END (179 LBS.)								41154050U	\$660		
CAST IRON SECTIONS - LEFT END (182 LBS.)								41154051U	\$660		
CAST IRON SECTIONS - INTERMEDIATE (165 LBS.)								41154052U	\$576		
COMPONENT CARTON - 300								550002861U	\$1,755		
COMPONENT CARTON - 400								550002862U	\$1,859		
COMPONENT CARTON - 500								550002863U	\$1,951		
COMPONENT CARTON - 300 CSD-1								550002890U	\$2,049		
COMPONENT CARTON - 400 CSD-1								550002891U	\$2,153		
COMPONENT CARTON - 500 CSD-1								550002892U	\$2,244		
END PANEL CARTON - JACKET								550002871U	\$255		
END PANEL CARTON - BASE								550002860U	\$231		
STEAM TRIM - SA 1 (SIZES/MODELS: 300 - 500)								41200061U	\$856		
STEAM TRIM - SA 2 (SIZES/MODELS: 600 - 700)								41200062U	\$869		
STEAM TRIM - SA 3 (SIZES/MODELS: 800 - 1400)								41200063U	\$892		
STEAM TRIM - SA 4 (SIZES/MODELS: 1500)								41200064U	\$917		
ACCESSORY CARTON - 300								550002877US	\$300		
ACCESSORY CARTON - 400								550002878US	\$354		
ACCESSORY CARTON - 500								550002867US	\$425		
ACCESSORY CARTON - 600								550002879US	\$481		
ACCESSORY CARTON - 700								550002880US	\$539		
ACCESSORY CARTON - 800								550002881US	\$602		
ACCESSORY CARTON - 900								550002882US	\$743		
ACCESSORY CARTON - 1000								550002868US	\$810		
ACCESSORY CARTON - 1100								550002883US	\$925		
ACCESSORY CARTON - 1200								550002884US	\$982		
ACCESSORY CARTON - 1300								550002885US	\$1,489		
ACCESSORY CARTON - 1400								550002886US	\$1,549		
ACCESSORY CARTON - 1500								550002869US	\$1,610		
CSD-1 STEAM TRIM - GRAVITY/CONDENSATE (ALL SIZES)								41257103U	\$389		
CSD-1 STEAM TRIM - FEED PUMP (ALL SIZES)								41257104U	\$1,091		
CSD-1 ACCESSORY CARTON - 300								550002893US	\$300		
CSD-1 ACCESSORY CARTON - 400								550002894US	\$354		
CSD-1 ACCESSORY CARTON - 500								550002895US	\$425		
CSD-1 ACCESSORY CARTON - 600								550002896US	\$961		
CSD-1 ACCESSORY CARTON - 700								550002897US	\$1,032		
CSD-1 ACCESSORY CARTON - 800								550002898US	\$1,095		
CSD-1 ACCESSORY CARTON - 900								550002899US	\$1,236		
CSD-1 ACCESSORY CARTON - 1000								550002900US	\$1,303		
CSD-1 ACCESSORY CARTON - 1100								550002901US	\$1,418		
CSD-1 ACCESSORY CARTON - 1200								550002902US	\$1,475		
CSD-1 ACCESSORY CARTON - 1300								550002903US	\$1,983		
CSD-1 ACCESSORY CARTON - 1400								550002904US	\$2,042		
CSD-1 ACCESSORY CARTON - 1500								550002905US	\$2,104		

JE SERIES STEAM CONTINUED		
(USE PARTS MULTIPLIER FOR ALL OF THE FOLLOWING)	PN	TRADE
STEAM MANUAL RESET PRESSURE CONTROL (L4079B1033)	14662311	\$266
M-M 47-2 LWCO & FEEDER (MODELS 300-1500)	1280001	\$1,194
STRAP ON OPERATING CONTROL (L6006C-1034)	14662313	\$160
LWCO, MAN RESET, CSD-1 APPROVED, SHT PROBE	240007388	\$212

**JE SERIES STEAM - STANDARD EQUIPMENT**

**STANDARD EQUIPMENT:**

JE Series Gas Fired Steam Boilers are low pressure, sectional, cast iron boilers manufactured in 15 heating sizes. Input range from 300,000 to 1,500,000 Btuh for use in larger sized residences, schools, churches, and commercial or industrial buildings. These boilers can be used in multiples to supply even larger loads. The JE Series Boiler is a modular design. Bases, Jackets and Drafthoods are designed in three modular sizes and all boilers are field assembled using a combination of one or more of these three modules. Boiler bases are preassembled at the factory with the gas valve, manifold, burners, and pilot installed. All drafthoods have a cleanout panel to provide easy access to flueways for inspection and cleaning. On-site boiler assembly is quick and easy with preassembled bases and easy section by section assembly procedures. The same assembly techniques are used on all sizes, so assemblers become familiar with the equipment and are able to reduce installation time and cost. Steam boilers are designed for use with a maximum working pressure of 15 psig.

STANDARD EQUIPMENT - STEAM: (67 Low Water Cut-Off, PA404A Pressuretrol and Syphon Loop, Water Gauge Glass Set with Glass and Rods, Steam Gauge, Pop Safety Valve).

**JE - COMPONENTS & OPTIONAL EQUIPMENT**

**CSD-1 CONTROL REQUIREMENTS**

The optional CSD-1 controls modify the standard JE boiler on both the fuel train and the steam trim as follows:

**STEAM BOILER WITH BOILER FEED PUMP RETURN SYSTEM**

- Add SF-500 Hydrolevel Safeguard Manual Reset L.W.C.O.
- Add 150S-B-MD L.W.C.O. and Pump Control
- Delete 67D-1 L.W.C.O.
- Add L404L Manual Reset Pressure Control

**STEAM BOILER WITH GRAVITY OR CONDENSATE PUMP RETURN SYSTEM**

- Add SF-500 Hydrolevel Safeguard Manual Reset L.W.C.O.
- Add L404C Manual Reset Pressure Control

The SF-500 L.W.C.O. is the secondary L.W.C.O. to the 67D-1 L.W.C.O. furnished standard with the boiler.

**FUEL TRAIN**

Substitute CSD-1 fuel train(s) for standard which includes (per base): Intermittent Pilot Module (PT#1140007) control Stop w/alarm 1003-612A & (PT#1140008) Control CSD1 Lockout Board BD 1145-2 with manual reset; Independent Pilot Gas Line (Manual shut-off valve, Pressure regulator, Safety shut-off valve); Main Gas Line (Gas Valve, Two leak test cocks, Manual shut-off downstream of the main gas valve).

**NOTES:**

1. The JE-300 and JE-400 do not require fuel train modifications for CSD-1. The standard fuel train is furnished.
2. Control equipment is included to meet Utica's interpretation of CSD-1. Consult local authorities before the installation of the boiler. Additional controls, if required can be provided at an additional price.

**TRIFIRE TRB SERIES**

OIL 3-PASS  
WATER BOILER

65 psi  
MAWP

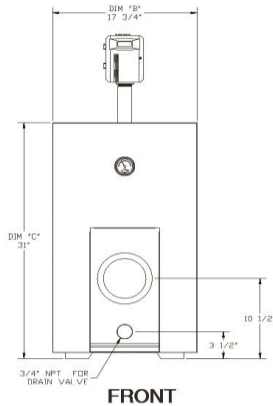
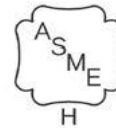

**FRONT**

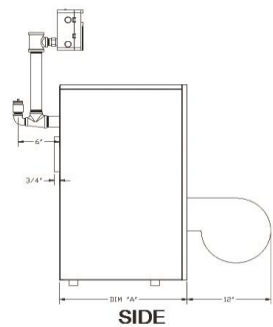

**SIDE**

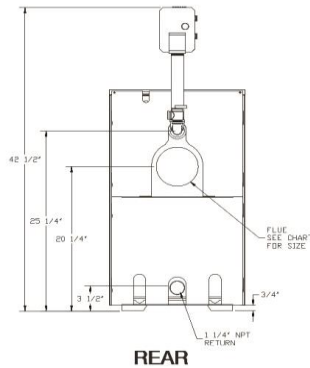

**REAR**



**General Information (See IOM for complete instructions)**

Clearances		Combustible Materials (Required) (1)	Accessibility, Cleaning & Servicing (2)
		<b>(1) Required distances measured from boiler jacket or flue.</b>	
	<b>Top</b>	12" (32 cm)	24" (61 cm)
	<b>Right Side</b>	2" (5 cm)	24" (61 cm)
	<b>Left Side</b>	2" (5 cm)	24" (61 cm)
<b>2) Accessibility, Cleaning &amp; Servicing recommendation.</b>			
	<b>Floor</b>	Combustible	N/A
	<b>Front</b>	17" (43 cm)	24" (61 cm)
	<b>Back</b>	See Flue	18" (46 cm)
	<b>Flue</b>	9" (23 cm)	9" (23 cm)
Connections	Return/Supply Water		
<b>All Models</b>	1-1/4" NPT		
Electrical	120 Volts AC, 60 hertz, 1 phase, Less than 12 amps (15 amp circuit recommended)		
Water Content	TRB4 - 3.6 Gallons, TRB5 - 4.3 Gallons, TRB6 - 5.1 Gallons, TRB7 - 5.9 Gallons		
Dimensions			
Model	A "Depth"	B "Width"	"C Height"
TRB4	18-3/8 (46 cm)	17-3/4" (45 cm)	31" (79 cm)
TRB5	21-5/8 (56 cm)	17-3/4" (45 cm)	31" (79 cm)
TRB6	24-7/8 (64 cm)	17-3/4" (45 cm)	31" (79 cm)
TRB7	28-1/8 (72 cm)	17-3/4" (45 cm)	31" (79 cm)

TRIFIRE TRB SERIES CONTINUED										
(BECKETT BURNER - CHIMNEY VENTED - HYDROLEVEL CONTROL - LESS PUMP)										
BOILER MODEL	ITEM NUMBER	TRADE PRICE	NO. OF SEC.	INPUT (MBH)	HTG. CAP. (MBH)	AHRI NET (MBH)	AFUE RATING %	CHIMNEY SIZE	FLUE DIA.	SHIP WGT.
TRB4075	TRB407530200210	\$2,449	4	105	91	79	86.0	8"x 8"x15'	5"	436
TRB4095	TRB409530200210	\$2,446	4	133	114	99	85.0		5"	436
TRB4110	TRB411030200210	\$2,449	4	154	132	115	84.0		5"	436
TRB5100	TRB510030200210	\$2,799	5	140	122	106	86.5		5"	496
TRB5115	TRB511530200210	\$2,799	5	161	139	121	85.0		5"	496
TRB5135	TRB513530200210	\$2,799	5	189	161	140	84.0		5"	496
TRB6130	TRB613030200210	\$2,955	6	182	159	138	86.5		5"	560
TRB6145	TRB614530200210	\$2,955	6	203	176	153	85.0		5"	560
TRB7165	TRB716530200210	\$3,379	7	231	201	175	86.0		6"	620
(BECKETT BURNER - CHIMNEY VENTED - HYDROLEVEL CONTROL - WITH TACO SYSTEM PUMP)										
BOILER MODEL	ITEM NUMBER	TRADE PRICE	NO. OF SEC.	INPUT (MBH)	HTG. CAP. (MBH)	AHRI NET (MBH)	AFUE RATING %	CHIMNEY SIZE	FLUE DIA.	SHIP WGT.
TRB4075	TRB407530210210	\$2,526	4	105	91	79	86.0	8"x 8"x15'	5"	436
TRB4095	TRB409530210210	\$2,526	4	133	114	99	85.0		5"	436
TRB4110	TRB411030210210	\$2,526	4	154	132	115	84.0		5"	436
TRB5100	TRB510030210210	\$2,875	5	140	122	106	86.5		5"	496
TRB5115	TRB511530210210	\$2,875	5	161	139	121	85.0		5"	496
TRB5135	TRB513530210210	\$2,875	5	189	161	140	84.0		5"	496
TRB6130	TRB613030210210	\$3,031	6	182	159	138	86.5		5"	560
TRB6145	TRB614530210210	\$3,031	6	203	176	153	85.0		5"	560
TRB7165	TRB716530210210	\$3,456	7	231	201	175	86.0		6"	620
(BECKETT BURNER - CHIMNEY VENTED - HYDROLEVEL CONTROL - WITH GRUNDFOS SYSTEM PUMP)										
BOILER MODEL	ITEM NUMBER	TRADE PRICE	NO. OF SEC.	INPUT (MBH)	HTG. CAP. (MBH)	AHRI NET (MBH)	AFUE RATING %	CHIMNEY SIZE	FLUE DIA.	SHIP WGT.
TRB4075	TRB407530220210	\$2,526	4	105	91	79	86.0	8"x 8"x15'	5"	436
TRB4095	TRB409530220210	\$2,526	4	133	114	99	85.0		5"	436
TRB4110	TRB411030220210	\$2,526	4	154	132	115	84.0		5"	436
TRB5100	TRB510030220210	\$2,875	5	140	122	106	86.5		5"	496
TRB5115	TRB511530220210	\$2,875	5	161	139	121	85.0		5"	496
TRB5135	TRB513530220210	\$2,875	5	189	161	140	84.0		5"	496
TRB6130	TRB613030220210	\$3,031	6	182	159	138	86.5		5"	560
TRB6145	TRB614530220210	\$3,031	6	203	176	153	85.0		5"	560
TRB7165	TRB716530220210	\$3,456	7	231	201	175	86.0		6"	620
(LESS BURNER - HYDROLEVEL CONTROL - WITH TACO SYSTEM PUMP)										
BOILER MODEL	ITEM NUMBER	TRADE PRICE	NO. OF SEC.	INPUT (MBH)	HTG. CAP. (MBH)	AHRI NET (MBH)	AFUE RATING %	CHIMNEY SIZE	FLUE DIA.	SHIP WGT.
TRB4110	TRB411020210210	\$1,902	4	154	132	115	84.0	8"x8"x15'	5"	436
TRB5135	TRB513520210210	\$2,216	5	189	161	140	84.0		5"	496
TRB6165	TRB616520210210	\$2,436	6	231	198	172	84.0		5"	560
TRB7190	TRB719020210210	\$2,804	7	266	228	198	84.0	8"x8"x20'	6"	620
(LESS BURNER - HYDROLEVEL CONTROL - WITH GRUNDFOS SYSTEM PUMP)										
BOILER MODEL	ITEM NUMBER	TRADE PRICE	NO. OF SEC.	INPUT (MBH)	HTG. CAP. (MBH)	AHRI NET (MBH)	AFUE RATING %	CHIMNEY SIZE	FLUE DIA.	SHIP WGT.
TRB4110	TRB411020220206	\$1,902	4	154	132	115	84.0	8"x8"x15'	5"	436
TRB5135	TRB513520220206	\$2,216	5	189	161	140	84.0		5"	496
TRB6165	TRB616520220206	\$2,436	6	231	198	172	84.0		5"	560
TRB7190	TRB719020220206	\$2,804	7	266	228	198	84.0	8"x8"x20'	6"	620

TRIFIRE TRB SERIES CONTINUED											
(LESS BURNER - CHIMNEY VENTED - HYDROLEVEL CONTROL - LESS PUMP)											
BOILER MODEL	ITEM NUMBER	TRADE PRICE	NO. OF SEC.	INPUT (MBH)	HTG. CAP. (MBH)	AHRI NET (MBH)	AFUE RATING %	CHIMNEY SIZE	FLUE DIA.	SHIP WGT.	
TRB4110	TRB411020200210	\$1,826	4	154	132	115	84.0	8"x8"x15'	5"	436	
TRB5135	TRB513520200210	\$2,139	5	189	161	140	84.0		5"	496	
TRB6165	TRB616520200210	\$2,360	6	231	198	172	84.0		5"	560	
TRB7190	TRB719020200210	\$2,727	7	266	228	198	84.0	8"x8"x20'	6"	620	
(BECKETT BURNER - DIRECT VENT - HYDROLEVEL CONTROL - LESS PUMP)											
BOILER MODEL	ITEM NUMBER	TRADE PRICE	NO. OF SEC.	INPUT (MBH)	HTG. CAP. (MBH)	AHRI NET (MBH)	AFUE RATING %	CHIMNEY SIZE	FLUE DIA.	SHIP WGT.	
TRB4075	TRB407540200210	\$2,621	4	105	91	79	86.0	8" x 8" x 15'	5"	436	
TRB4095	TRB409540200210	\$2,621	4	133	114	99	85.0		5"	436	
TRB5100	TRB510040200210	\$2,969	5	140	122	106	86.5		5"	496	
TRB5115	TRB511540200210	\$2,969	5	161	139	121	85.0		5"	496	
TRB5135	TRB513540200210	\$2,969	5	189	161	140	84.0		5"	496	
TRB6130	TRB613040200210	\$3,126	6	182	159	138	86.5		5"	560	
TRB6130	TRB613040200210	\$3,126	6	182	159	138	86.5		5"	560	
(BECKETT BURNER - DIRECT VENT - HYDROLEVEL CONTROL - WITH TACO SYSTEM PUMP)											
BOILER MODEL	ITEM NUMBER	TRADE PRICE	NO. OF SEC.	INPUT (MBH)	HTG. CAP. (MBH)	AHRI NET (MBH)	AFUE RATING %	CHIMNEY SIZE	FLUE DIA.	SHIP WGT.	
TRB4075	TRB407540210210	\$2,698	4	105	91	79	86.0	8" x 8" x 15'	5"	436	
TRB4095	TRB409540210210	\$2,698	4	133	114	99	85.0		5"	436	
TRB5100	TRB510040210210	\$3,046	5	140	122	106	86.5		5"	496	
TRB5115	TRB511540210210	\$3,046	5	161	139	121	85.0		5"	496	
TRB5135	TRB513540210210	\$3,046	5	189	161	140	84.0		5"	496	
TRB6130	TRB613040210210	\$3,203	6	182	159	138	86.5		5"	560	
TRB6130	TRB613040210210	\$3,203	6	182	159	138	86.5		5"	560	
(BECKETT BURNER - DIRECT VENT - HYDROLEVEL CONTROL - WITH GRUNDFOS SYSTEM PUMP)											
BOILER MODEL	ITEM NUMBER	TRADE PRICE	NO. OF SEC.	INPUT (MBH)	HTG. CAP. (MBH)	AHRI NET (MBH)	AFUE RATING %	CHIMNEY SIZE	FLUE DIA.	SHIP WGT.	
TRB4075	TRB407540220210	\$2,698	4	105	91	79	86.0	8" x 8" x 15'	5"	436	
TRB4095	TRB409540220210	\$2,698	4	133	114	99	85.0		5"	436	
TRB5100	TRB510040220210	\$3,046	5	140	122	106	86.5		5"	496	
TRB5115	TRB511540220210	\$3,046	5	161	139	121	85.0		5"	496	
TRB5135	TRB513540220210	\$3,046	5	189	161	140	84.0		5"	496	
TRB6130	TRB613040220210	\$3,203	6	182	159	138	86.5		5"	560	
TRB6130	TRB613040220210	\$3,203	6	182	159	138	86.5		5"	560	
(RIELLO BURNER - CHIMNEY VENTED - LESS PUMP)											
BOILER MODEL	ITEM NUMBER	TRADE PRICE	NO. OF SEC.	INPUT (MBH)	HTG. CAP. (MBH)	AHRI NET (MBH)	AFUE RATING %	CHIMNEY SIZE	FLUE DIA.	SHIP WGT.	
TRB4075	TRB407550200210	\$2,561	4	105	91	79	86.0	8" x 8" x 15'	5"	436	
TRB4095	TRB409550200210	\$2,561	4	133	114	99	85.0		5"	436	
TRB4110	TRB411050200210	\$2,561	4	154	132	115	84.0		5"	436	
TRB5100	TRB510050200210	\$2,956	5	140	122	106	86.5		5"	496	
TRB5115	TRB511550200210	\$2,956	5	161	139	121	85.0		5"	496	
TRB5135	TRB513550200210	\$2,956	5	189	161	140	84.0		5"	496	
TRB6130	TRB613050200210	\$3,111	6	182	159	138	86.5		5"	560	
TRB6145	TRB614550200210	\$3,111	6	203	176	153	85.0		5"	560	
TRB6165	TRB616550200210	\$3,394	6	231	198	172	84.0		5"	560	
TRB7165	TRB716550200210	\$3,379	7	231	201	175	86.0		6"	620	
TRB7180	TRB718050200210	\$3,762	7	252	217	189	85.0		6"	620	
TRB7190	TRB719050200210	\$3,762	7	266	228	198	84.0		8" x 8" x 20'	6"	620



TRIFIRE TRB SERIES CONTINUED										
(RIELLO BURNER - CHIMNEY VENTED - WITH TACO SYSTEM PUMP)										
BOILER MODEL	ITEM NUMBER	TRADE PRICE	NO. OF SEC.	INPUT (MBH)	HTG. CAP. (MBH)	AHRI NET (MBH)	AFUE RATING %	CHIMNEY SIZE	FLUE DIA.	SHIP WGT.
TRB4075	TRB407550210210	\$2,638	4	105	91	79	86.0	8"x 8"x15'	5"	436
TRB4095	TRB409550210210	\$2,638	4	133	114	99	85.0		5"	436
TRB4110	TRB411050210210	\$2,638	4	154	132	115	84.0		5"	436
TRB5100	TRB510050210210	\$3,032	5	140	122	106	86.5		5"	496
TRB5115	TRB511550210210	\$3,032	5	161	139	121	85.0		5"	496
TRB5135	TRB513550210210	\$3,032	5	189	161	140	84.0		5"	496
TRB6130	TRB613050210210	\$3,187	6	182	159	138	86.5		5"	560
TRB6145	TRB614550210210	\$3,187	6	203	176	153	85.0		5"	560
TRB6165	TRB616550210210	\$3,470	6	231	198	172	84.0		5"	560
TRB7165	TRB716550210210	\$3,456	7	231	201	175	86.0		6"	620
TRB7180	TRB718050210210	\$3,839	7	252	217	189	85.0	6"	620	
TRB7190	TRB719050210210	\$3,839	7	266	228	198	84.0	8"x 8"x20'	6"	620
TRIFIRE TRB SERIES CONTINUED										
(RIELLO BURNER - CHIMNEY VENTED - WITH GRUNDFOS SYSTEM PUMP)										
BOILER MODEL	ITEM NUMBER	TRADE PRICE	NO. OF SEC.	INPUT (MBH)	HTG. CAP. (MBH)	AHRI NET (MBH)	AFUE RATING %	CHIMNEY SIZE	FLUE DIA.	SHIP WGT.
TRB4075	TRB407550220210	\$2,638	4	105	91	79	86.0	8"x 8"x15'	5"	436
TRB4095	TRB409550220210	\$2,638	4	133	114	99	85.0		5"	436
TRB4110	TRB411050220210	\$2,638	4	154	132	115	84.0		5"	436
TRB5100	TRB510050220210	\$3,032	5	140	122	106	86.5		5"	496
TRB5115	TRB511550220210	\$3,032	5	161	139	121	85.0		5"	496
TRB5135	TRB513550220210	\$3,032	5	189	161	140	84.0		5"	496
TRB6130	TRB613050220210	\$3,187	6	182	159	138	86.5		5"	560
TRB6145	TRB614550220210	\$3,187	6	203	176	153	85.0		5"	560
TRB6165	TRB616550220210	\$3,470	6	231	198	172	84.0		5"	560
TRB7165	TRB716550220210	\$3,456	7	231	201	175	86.0		6"	620
TRB7180	TRB718050220210	\$3,839	7	252	217	189	85.0	6"	620	
TRB7190	TRB719050220210	\$3,839	7	266	228	198	84.0	8"x 8"x20'	6"	620
(RIELLO 40BF BURNER - DIRECT VENT - LESS PUMP)										
BOILER MODEL	ITEM NUMBER	TRADE PRICE	NO. OF SEC.	INPUT (MBH)	HTG. CAP. (MBH)	AHRI NET (MBH)	AFUE RATING %	CHIMNEY SIZE	FLUE DIA.	SHIP WGT.
TRB4075	TRB407560200210	\$2,898	4	105	91	79	86.0	8"x 8" x15'	5"	436
TRB4095	TRB409560200210	\$2,898	4	133	114	99	85.0		5"	436
TRB4110	TRB411060200210	\$2,898	4	154	132	115	84.0		5"	436
TRB5100	TRB510060200210	\$3,292	5	140	122	106	86.5		5"	496
TRB5115	TRB511560200210	\$3,292	5	161	139	121	85.0		5"	496
TRB5135	TRB513560200210	\$3,292	5	189	161	140	84.0		5"	496
TRB6130	TRB613060200210	\$3,445	6	182	159	138	86.5		5"	560

TRIFIRE TRB SERIES CONTINUED										
(RIELLO BURNER - DIRECT VENT - WITH TACO SYSTEM PUMP)										
BOILER MODEL	ITEM NUMBER	TRADE PRICE	NO. OF SEC.	INPUT (MBH)	HTG. CAP. (MBH)	AHRI NET (MBH)	AFUE RATING %	CHIMNEY SIZE	FLUE DIA.	SHIP WGT.
TRB4075	TRB407560210210	\$2,975	4	105	91	79	86.0	8"x 8" x15'	5"	436
TRB4095	TRB409560210210	\$2,975	4	133	114	99	85.0		5"	436
TRB4110	TRB411060210210	\$2,975	4	154	132	115	84.0		5"	436
TRB5100	TRB510060210210	\$3,368	5	140	122	106	86.5		5"	496
TRB5115	TRB511560210210	\$3,368	5	161	139	121	85.0		5"	496
TRB5135	TRB513560210210	\$3,368	5	189	161	140	84.0		5"	496
TRB6130	TRB613060210210	\$3,523	6	182	159	138	86.5		5"	560
<b>(RIELLO 40BF BURNER - DIRECT VENT - WITH GRUNDFOS SYSTEM PUMP)</b>										
BOILER MODEL	ITEM NUMBER	TRADE PRICE	NO. OF SEC.	INPUT (MBH)	HTG. CAP. (MBH)	AHRI NET (MBH)	AFUE RATING %	CHIMNEY SIZE	FLUE DIA.	SHIP WGT.
TRB4075	TRB407560220210	\$2,975	4	105	91	79	86.0	8"x 8" x15'	5"	436
TRB4095	TRB409560220210	\$2,975	4	133	114	99	85.0		5"	436
TRB4110	TRB411060220210	\$2,975	4	154	132	115	84.0		5"	436
TRB5100	TRB510060220210	\$3,368	5	140	122	106	86.5		5"	496
TRB5115	TRB511560220210	\$3,368	5	161	139	121	85.0		5"	496
TRB5135	TRB513560220210	\$3,368	5	189	161	140	84.0		5"	496
TRB6130	TRB613060220210	\$3,523	6	182	159	138	86.5		5"	560
TRIFIRE TRB SERIES - VENTING OPTIONS/ADD. EQUIPMENT							PN		TRADE	
36" RISER TERMINATION							29231U	\$1,119		
STANDARD TERMINATION							28972U	\$462		
4" ID X 10 FT DIRECT VENT PIPE KIT (SELECT TERMINATION)							240006909U	\$379		
4" ID X 15 FT DIRECT VENT PIPE KIT (SELECT TERMINATION)							240006910U	\$500		
4" ID X 20 FT DIRECT VENT PIPE KIT (SELECT TERMINATION)							240006911U	\$618		
(USE PARTS MULTIPLIER FOR ALL OF THE FOLLOWING)							PN	TRADE		
KIT, HIGH LIMIT MANUAL RESET L4006E1109 WITH PLUG IN HARNESS							550001929	\$212		
FILL-TROL FOR WATER BOILERS 150 MBH OR LESS							14624002	\$291		
FILL-TROL FOR WATER BOILERS OVER 150 MBH							14624003	\$392		
REPLACEMENT BURNERS										
DESCRIPTION						MODEL	PN	TRADE		
Oil Burner - Beckett Chimney Vent w/o Cover Model AFG except 5115 & 5135 use Model NX						4075	240007232U	\$624		
						4095	240009385U	\$624		
						4110	240009386U	\$624		
						5100	240007233U	\$660		
						5115	240009387U	\$660		
						5135	240009388U	\$702		
						6130	240007234U	\$595		
						6145	240009389U	\$595		
						7165	240007235U	\$651		

**TRIFIRE TRB SERIES CONTINUED  
REPLACEMENT BURNERS**

Oil Burner - Same as above w/Cover	4075	240007144U	\$666
	4095	240009377U	\$666
	4110	240009378U	\$666
	5100	240007145U	\$702
	5115	240009379U	\$702
	5135	240009380U	\$702
	6130	240007146U	\$639
	6145	240009381U	\$639
	7165	240007183U	\$694
Oil Burner - Beckett Direct Vent Model NX	4075	240007531U	\$796
	4095	240009393U	\$796
	5100	240007532U	\$830
	5115	240009395U	\$830
	5135	240009396U	\$830
	6130	240007533U	\$767
Oil Burner - Riello Chimney Vent Model 40F	4075	240007502U	\$734
	4095	240009399U	\$734
	4110	240009400U	\$734
	5100	240007503U	\$817
	5115	240009401U	\$817
	5135	550002638U	\$817
	6130	550002639U	\$751
	6145	550002640U	\$751
	6165	240009404U	\$1,034
	7165	240007505U	\$751
	7180	550002641U	\$1,034
Oil Burner - Riello Direct Vent Model 40BF	7190	240009406U	\$1,034
	4075	240007528U	\$1,072
	4095	240009407U	\$1,072
	4110	240009408U	\$1,072
	5100	240007529U	\$1,153
	5115	240009409U	\$1,153
	5135	240009410U	\$1,153
Oil Burner - Carlin EZ-LF	6130	240007530U	\$1,088
	4075	240010357U	\$672
	4095		
	4110		
	5100		
	5115		
5135			

**TRIFIRE TRB SERIES CONTINUED**

**TRIFIRE TRB - STANDARD EQUIPMENT**

**STANDARD EQUIPMENT:**

- Boiler Control Module: Hydrolevel Fuel Smart HydroStat Control - combination Low Water Cut Off with boiler temperature reset and circulator control.
- User Display Interface: Digital display with easy to set dial-type limit settings.
- Heat Exchanger: High efficiency, cast iron, 3-pass design with reversible swing door and target wall. Efficiency baffles/liner by model.
- Combustion: Oil burner, flexible oil line.
- Electrical: Wiring harness with Molex connectors. Burner with electrical plug in cord.
- Other: Temperature/pressure gauge, 3/4" ASME relief valve, drain valve, textured painted steel jacket.

**STARFIRE SFH-IV SERIES**

OIL CHIMNEY VENT

WATER BOILER



**Front View**

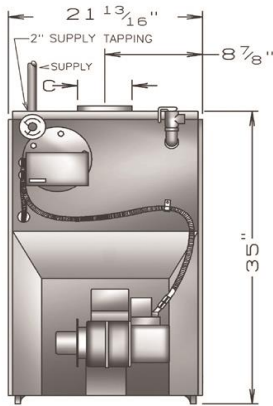

**General Information** (See IOM for complete instructions)

<b>Clearances</b>		<b>Combustible Materials (Required) (1)</b>
<b>(1) Required distances measured from boiler.</b>	<b>Top</b>	24" (610 mm)
	<b>Front</b>	24" (610 mm)
	<b>Flue Connector</b>	9" (229 mm)
	<b>Rear</b>	6" (152 mm)
	<b>Sides</b>	6" (152 mm)
<b>Connections</b>	Supply Tapping - 2", Return Tapping 1-1/2" NPT, Oil Line 3/8" O.D. copper tubing for runs of 50 feet or less, and 1/2" O.D. for longer runs.	
<b>All Models</b>	120 Volts AC, 60 hertz, 1 phase, Less than 12 amps (15 amp circuit recommended)	
<b>Electrical</b>	SFH3 - 10.5 Gallons, SFH4 - 13.5 Gallons, SFH5 - 16.5 Gallons, SFH6 - 19.5 Gallons	
<b>Water Content</b>		

**Side View**

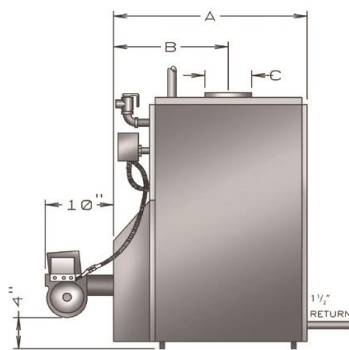

Model	Input Rate G.P.H.	Tankless Heater Number	Tankless Heater Cap. Intermittent Draw
SFH-3085WT	0.85	T3	3
SFH-3100WT	1.00	T3	3.25
SFH-4100WT	1.00	T4	3.25
SFH-4125WT	1.25	T4	3.75
SFH-4145WT	1.45	T4	4
SFH-5160WT	1.60	T4	4
SFH-5185WT	1.85	T4	4.25
SFH-6175WT	1.75	T4	4.25
SFH-6210WT	2.10	T4	4.5

**Dimensions**

Number of Sections	A (Depth of Flush Jacket)	B (Front of Jacket to Center Line of Flue Outlet)	C (Flue Outlet Diameter)
3	17-7/8"	11-1/4"	6"
4	21-1/2"	12-5/8"	6"
5	25-1/8"	14-1/4"	7"
6	29-1/4"	15-15/16"	8"

STARFIRE SFH-IV SERIES WATER CONTINUED									
(BECKETT BURNER - CHIMNEY VENTED - TACO SYSTEM PUMP - CAST OVER - STANDARD)									
BOILER MODEL	ITEM NUMBER	TRADE PRICE	NO. OF SEC.	INPUT (MBH)	HTG. CAP. (MBH)	AHRI NET (MBH)	FIRING RATE G.P.H.	AFUE RATING %	SHIP WGT.
SFH-3085W	SFH308530110410	\$3,249	3	119	103	90	0.85	85.0	534
SFH-3100W	SFH310030110410	\$3,249	3	140	119	103	1.00	84.0	534
SFH-4100W	SFH410030110410	\$3,714	4	140	122	106	1.00	86.0	668
SFH-4125W	SFH412530110410	\$3,714	4	175	151	131	1.25	85.0	668
SFH-4145W	SFH414530110410	\$3,714	4	203	173	150	1.45	84.0	668
SFH-5160W	SFH516030110410	\$4,213	5	224	193	168	1.60	85.0	781
SFH-5185W	SFH518530110410	\$4,213	5	259	221	192	1.85	84.0	781
SFH-6175W	SFH617530110410	\$4,607	6	245	212	184	1.75	85.0	901
SFH-6210W	SFH621030110410	\$4,607	6	294	252	219	2.10	84.0	901
(BECKETT BURNER - CHIMNEY VENTED - TACO SYSTEM PUMP - WITH TANKLESS COVER PLATE)									
BOILER MODEL	ITEM NUMBER	TRADE PRICE	NO. OF SEC.	INPUT (MBH)	HTG. CAP. (MBH)	AHRI NET (MBH)	FIRING RATE G.P.H.	AFUE RATING %	SHIP WGT.
SFH-3085W	SFH308531110410	\$3,368	3	119	103	90	0.85	85.0	534
SFH-3100W	SFH310031110410	\$3,368	3	140	119	103	1.00	84.0	534
SFH-4100W	SFH410031110410	\$3,843	4	140	122	106	1.00	86.0	668
SFH-4125W	SFH412531110410	\$3,843	4	175	151	131	1.25	85.0	668
SFH-4145W	SFH414531110410	\$3,843	4	203	173	150	1.45	84.0	668
SFH-5160W	SFH516031110410	\$4,351	5	224	193	168	1.60	85.0	781
SFH-5185W	SFH518531110410	\$4,351	5	259	221	192	1.85	84.0	781
SFH-6175W	SFH617531110410	\$4,753	6	245	212	184	1.75	85.0	901
SFH-6210W	SFH621031110410	\$4,753	6	294	252	219	2.10	84.0	901
(BECKETT BURNER - CHIMNEY VENTED - TACO SYSTEM PUMP - WITH TANKLESS COIL)									
BOILER MODEL	ITEM NUMBER	TRADE PRICE	NO. OF SEC.	INPUT (MBH)	HTG. CAP. (MBH)	AHRI NET (MBH)	FIRING RATE G.P.H.	AFUE RATING %	SHIP WGT.
SFH-3085WT	SFH308532110410	\$3,514	3	119	103	90	0.85	85.0	534
SFH-3100WT	SFH310032110410	\$3,514	3	140	119	103	1.00	84.0	534
SFH-4100WT	SFH410032110410	\$4,030	4	140	122	106	1.00	86.0	668
SFH-4125WT	SFH412532110410	\$4,030	4	175	151	131	1.25	85.0	668
SFH-4145WT	SFH414532110410	\$4,030	4	203	173	150	1.45	84.0	668
SFH-5160WT	SFH516032110410	\$4,490	5	224	193	168	1.60	85.0	781
SFH-5185WT	SFH518532110410	\$4,490	5	259	221	192	1.85	84.0	781
SFH-6175WT	SFH617532110410	\$4,878	6	245	212	184	1.75	85.0	901
SFH-6210WT	SFH621032110410	\$4,878	6	294	252	219	2.10	84.0	901
(LESS BURNER - CHIMNEY VENTED - TACO SYSTEM PUMP - CAST OVER - STANDARD)									
BOILER MODEL	ITEM NUMBER	TRADE PRICE	NO. OF SEC.	INPUT (MBH)	HTG. CAP. (MBH)	AHRI NET (MBH)	FIRING RATE G.P.H.	AFUE RATING %	SHIP WGT.
SFH-3100W	SFH310020110410	\$2,448	3	140	119	103	1.00	84.0	534
SFH-4145W	SFH414520110410	\$2,876	4	203	173	150	1.45	84.0	668
SFH-5185W	SFH518520110410	\$3,361	5	259	221	192	1.85	84.0	781
SFH-6210W	SFH621020110410	\$3,740	6	294	252	219	2.10	84.0	901
(LESS BURNER - CHIMNEY VENTED - LESS PUMP - CAST OVER)									
BOILER MODEL	ITEM NUMBER	TRADE PRICE	NO. OF SEC.	INPUT (MBH)	HTG. CAP. (MBH)	AHRI NET (MBH)	FIRING RATE G.P.H.	AFUE RATING %	SHIP WGT.
SFH-3100W	SFH310020100410	\$2,371	3	140	119	103	1.00	84.0	534
SFH-4145W	SFH414520100410	\$2,800	4	203	173	150	1.45	84.0	668
SFH-5185W	SFH518520100410	\$3,285	5	259	221	192	1.85	84.0	781
SFH-6210W	SFH621020100410	\$3,664	6	294	252	219	2.10	84.0	901

STARFIRE SFH-IV SERIES CONTINUED									
(LESS BURNER - CHIMNEY VENTED - TACO SYSTEM PUMP - WITH TANKLESS COIL)									
BOILER MODEL	ITEM NUMBER	TRADE PRICE	NO. OF SEC.	INPUT (MBH)	HTG. CAP. (MBH)	AHRI NET (MBH)	FIRING RATE G.P.H.	AFUE RATING %	SHIP WGT.
SFH-3100WT	SFH310022110410	\$2,715	3	140	119	103	1.00	84.0	534
SFH-4145WT	SFH414522110410	\$3,192	4	203	173	150	1.45	84.0	668
SFH-5185WT	SFH518522110410	\$3,639	5	259	221	192	1.85	84.0	781
SFH-6210WT	SFH621022110410	\$4,010	6	294	252	219	2.10	84.0	901
(LESS BURNER - CHIMNEY VENTED - LESS PUMP - WITH TANKLESS COIL)									
BOILER MODEL	ITEM NUMBER	TRADE PRICE	NO. OF SEC.	INPUT (MBH)	HTG. CAP. (MBH)	AHRI NET (MBH)	FIRING RATE G.P.H.	AFUE RATING %	SHIP WGT.
SFH-3100WT	SFH310022100410	\$2,639	3	140	119	103	1.00	84.0	534
SFH-4145WT	SFH414522100410	\$3,116	4	203	173	150	1.45	84.0	668
SFH-5185WT	SFH518522100410	\$3,563	5	259	221	192	1.85	84.0	781
SFH-6210WT	SFH621022100410	\$3,934	6	294	252	219	2.10	84.0	901

STARFIRE SFH-IV SERIES - OPTIONS/ADD. EQUIPMENT	PN	TRADE
3085/3011 BECKETT RERATE KIT (Used on 3 section SFH IV .85 and 1.00 Firing Rates)	550002372	\$64
4100/4125/4145 BECKETT RERATE KIT (Used on 4 section SFH IV 1.00, 1.25, 1.45 Firing Rates)	550002373	\$64
5160/5185 BECKETT RERATE KIT (Used on 5 section SFH IV 1.50 and 1.85 Firing Rates)	550002374	\$64
SFH-3085/3100 BECKETT BURNER IN A BOX KIT (SFH IV 3 section boiler)	550002680	\$799
SFH-4100/4125/4145 BECKETT BURNER IN A BOX KIT (SFH IV 4 section boiler)	550002681	\$838
SFH-5150/5185 BECKETT BURNER IN A BOX KIT (SFH IV 5 section boiler)	550002682	\$852
SFH-6175/6210 BECKETT BURNER IN A BOX KIT (SFH IV 6 section boiler)	550002683	\$868
SFH 3085/3100/4100/4125/4145/5160 RIELLO 40F5 BURNER IN A BOX KIT	550002832	\$1,008
SFH 5160/5185 RIELLO 40F10 BURNER IN A BOX KIT	550002833	\$1,327
SFH 6175/6210 RIELLO 40F10 BURNER IN A BOX KIT	550002834	\$1,337
SFH 3085/3100/4100/4125/4145 CARLIN EZ1-HP BURNER IN A BOX KIT	240010414	\$783
SFH 5160/5185/6175/6210 CARLIN EZ2-HP BURNER IN A BOX KIT	240010415	\$783

**STARFIRE SFH-IV SERIES - STANDARD EQUIPMENT**

**STANDARD EQUIPMENT:**

- Boiler Controls: Primary Control, High Limit and Circulator Control
- Heat Exchanger: Cast Iron Heat Exchanger with Cast Iron Push Nipples. Swing out Burner Door.
- Combustion: Oil Burner, Target Wall/Liner.
- Electrical: Wiring Harness, Burner Electrical Disconnect.
- Other: Crated Boiler, Flush Jacket, Circulator- 1¼", Supply Tapping-2", Return Tapping-1 1/2", Temperature Pressure Gauge, Safety Relief Valve, Drain Valve.
- For Tankless Heater Units add Tankless Hot Water Coil and Triple Combination High Limit/Low

**STARFIRE SW II SERIES**

OIL SIDE-WALL VENT

WATER BOILER

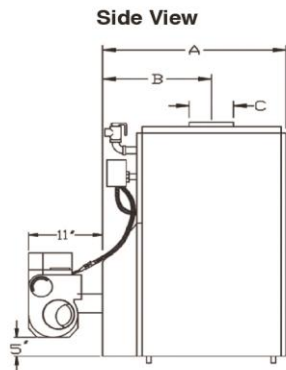
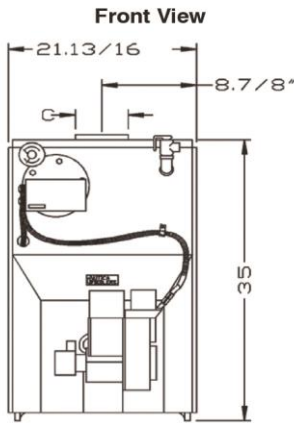

**General Information** (See IOM for complete instructions)

Clearances		Combustible Materials (Required) (1)	Servicing (2)
(1) Required distances measured from boiler.	Top	0" (0 mm)	24" (610 mm)
	Right Side	0" (0 mm)	6" (152 mm)
	Left Side	0" (0 mm)	10" (254 mm)
(2) Service, proper operation clearance recommendation.	Front	24" (610 mm)	24" (610 mm)
	Back	6" (152 mm)	6" (152 mm)
	Flue Connector	2" (50.8 mm)	9" (228.6 mm)
	Connections	Supply Tapping - 2", Return Tapping 1-1/2" NPT, Oil Line 3/8" O.D. copper tubing for runs of 50 feet or less, and 1/2" O.D. for longer runs.	
All Models	120 Volts AC, 60 hertz, 1 phase, Less than 12 amps (15 amp circuit recommended)		
Electrical	SW3 - 10.5 Gallons, SW4 - 13.5 Gallons, SW5 - 16.5 Gallons		
Water Content			
Model	Input Rate G.P.H.	Tankless Heater Number	Tankless Heater Cap. Intermittent Draw
SW3065	0.65	P3	Avail. On Req.
SW4100	1.00	T3	3.25
SW5125	1.25	T4	3.25
Dimensions			
Number of Sections	A (Depth of Flush Jacket)	B (Front of Jacket to Center Line of Flue Outlet)	C (Flue Outlet Diameter)
3	17-7/8"	11-1/4"	4"
4	21-1/2"	12-5/8"	4"
5	25-1/8"	14-1/4"	4"

SW II SERIES WATER CONTINUED									
(BECKETT BURNER - SIDEWALL VENTED - TACO SYSTEM PUMP - WITH TANKLESS COVER PLATE)									
BOILER MODEL	ITEM NUMBER	TRADE PRICE	NO. OF SEC.	INPUT (MBH)	HTG. CAP. (MBH)	AHRI NET (MBH)	FIRING RATE G.P.H.	AFUE RATING %	SHIP WGT.
SW3065	SWB30654011021	\$3,648	3	91	78	68	0.65	85.0	561
SW4100	SWB41004011021	\$4,083	4	140	120	104	1.00	85.0	690
SW5125	SWB51254011021	\$4,503	5	175	150	130	1.25	85.0	819
(BECKETT BURNER - SIDEWALL VENTED - TACO SYSTEM PUMP - WITH TANKLESS COIL)									
BOILER MODEL	ITEM NUMBER	TRADE PRICE	NO. OF SEC.	INPUT (MBH)	HTG. CAP. (MBH)	AHRI NET (MBH)	FIRING RATE G.P.H.	AFUE RATING %	SHIP WGT.
SW3065	SWB30654211021	\$4,003	3	91	78	68	0.65	85.0	561
SW4100	SWB41004211021	\$4,313	4	140	120	104	1.00	85.0	690
SW5125	SWB51254211021	\$4,767	5	175	150	130	1.25	85.0	819
SW II SERIES - VENTING OPTIONS/ADD. EQUIPMENT							PN	TRADE	
DIRECT VENT TERMINATION							28972U	\$462	
10' x 4" FLEXIBLE VENT PIPE							240006922U	\$509	
SW II SERIES - STANDARD EQUIPMENT									
<p><b><u>STANDARD EQUIPMENT:</u></b></p> <ul style="list-style-type: none"> <li>- Boiler Controls: Primary Control, High Limit and Circulator Control.</li> <li>- Heat Exchanger: Cast Iron Heat Exchanger with Cast Iron Push Nipples. Swing out Burner Door.</li> <li>Combustion: Oil Burner, Target Wall/Liner.</li> <li>- Electrical: Wiring Harness, Burner Electrical Disconnect.</li> <li>- Other: Crated Boiler, Flush Jacket, Circulator- 1¼", Supply Tapping-2", Return Tapping-1 1/4", Temperature Pressure Gauge, Safety Relief Valve, Drain Valve.</li> <li>- For Tankless Heater Units add Tankless Hot Water Coil and Combination High Limit/Low Limit and Circulator Control.</li> </ul>									



**SFE IV SERIES**

OIL  
STEAM BOILER



H  
Tested for 15 psi ASME  
Working Pressure

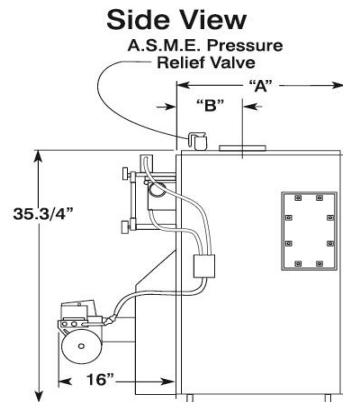
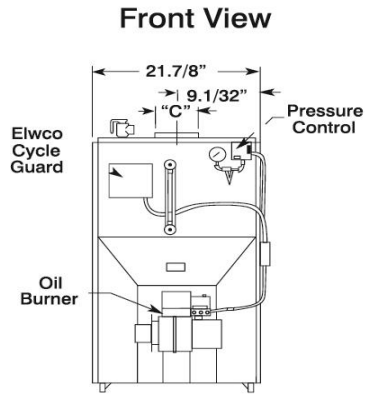

**General Information** (See IOM for complete instructions)

<b>Clearances</b>	<b>Combustible Materials (Required) (1)</b>	
	<b>Top</b>	24" (610 mm)
	<b>Left Side (Control Side)</b>	6" (152 mm)
	<b>Right Side</b>	24" (610 mm)
	<b>Front</b>	24" (610 mm)
	<b>Back</b>	24" (610 mm)
	<b>Flue Connector</b>	9" (229 mm)
<b>(1) Required distances measured from boiler.</b>		
<b>Connections</b>	Supply Tapping Two 2" NPT, Return Tapping 1-1/2", Oil Line 3/8" O.D. copper tubing for runs of 50 feet or less, and 1/2" O.D. for longer runs.	
<b>Electrical</b>	120 Volts AC, 60 hertz, 1 phase, Less than 12 amps (15 amp circuit recommended)	

**Tankless Heater Capacities**

Model	Input Rate G.P.H.	Tank-less Heater Number	Tankless Heater Capacity Intermittent Draw G.P.M.	Boiler Water Content (Gallons)	
				To Water Line	To LWCO Line
SFE-3090ST	0.90	L-24	2.0	11	8
SFE-4125ST	1.25		4.5	13	9
SFE-5185ST	1.85		4.5	15	10
SFE-6210ST	2.10		4.5	15	10

**Dimensions**

No. of Sec.	A (Length of Flush Jacket)	B (Front of Jacket to Center Line of Flue Outlet)	C (Flue Outlet Diameter)
3	16-3/8"	6-1/2"	6"
4	20-1/4"	8-1/2"	6"
5	23-5/8"	10-1/4"	7"
6	27-1/2"	8-5/16"	8"

SFE IV SERIES CONTINUED										
(BECKETT BURNER - WITH TANKLESS COVER PLATE)										
BOILER MODEL	ITEM NUMBER	TRADE PRICE	No. of Sec.	INPUT (MBH)	HTG. CAP. (MBH)	AHRI NET (MBH)	AHRI NET SQ. FT. STEAM	Fir. Rate GPH	AFUE RATING %	SHIP WGT.
SFE-3090S	SFE309031100410	\$3,478	3	126	106	80	333	0.90	82.0%	534
SFE-4125S	SFE412531100410	\$4,016	4	175	147	110	458	1.25	82.0%	688
SFE-5185S	SFE518531100410	\$4,354	5	259	216	162	675	1.85	82.0%	781
SFE-6210S	SFE621031100410	\$4,760	6	294	247	185	771	2.10	82.0%	901
(BECKETT BURNER - WITH TANKLESS COIL)										
BOILER MODEL	ITEM NUMBER	TRADE PRICE	No. of Sec.	INPUT (MBH)	HTG. CAP. (MBH)	AHRI NET (MBH)	AHRI NET SQ. FT. STEAM	Fir. Rate GPH	AFUE RATING %	SHIP WGT.
SFE-3090ST	SFE309032100410	\$3,896	3	126	106	80	333	0.90	82.0%	534
SFE-4125ST	SFE412532100410	\$4,433	4	175	147	110	458	1.25	82.0%	688
SFE-5185ST	SFE518532100410	\$4,772	5	259	216	162	675	1.85	82.0%	781
SFE-6210ST	SFE621032100410	\$5,176	6	294	247	185	771	2.10	82.0%	901
SFE IV SERIES - STANDARD EQUIPMENT										
<p><b><u>STANDARD EQUIPMENT:</u></b></p> <ul style="list-style-type: none"> <li>- Boiler Controls: Honeywell Pressuretrol, Boiler Water Level Gauge Glass, and Steam Pressure Gauge.</li> <li>- Heat Exchanger: Cast Iron Heat Exchanger with Cast Iron Push Nipples, Swing Door.</li> <li>- Combustion: Beckett Oil Burner, Target Wall/Liner.</li> <li>- Electrical: Wiring Harness, Burner Electric Disconnect.</li> <li>- Safety: Electronic Low Water Cut Off.</li> <li>- Other: Crated Boiler, Flush Jacket, ASME Relief Valve, Drain Valve, Plastic Cover, Two 2" Supply Tappings, 1-1/2" Return Tapping and Skim Port.</li> <li>- For Tankless Heater Units: Add Tankless Hot Water Coil and 4006 Limit Control.</li> </ul>										

**BC SERIES II**

OIL  
WATER BOILER



Maximum Allowable Working Pressure 30 psi.

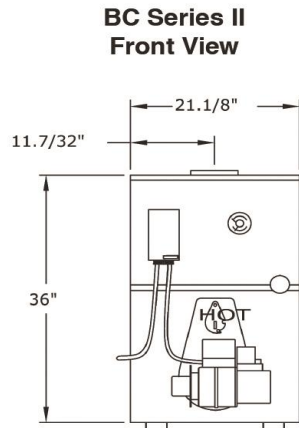

**BC Series II Side View**

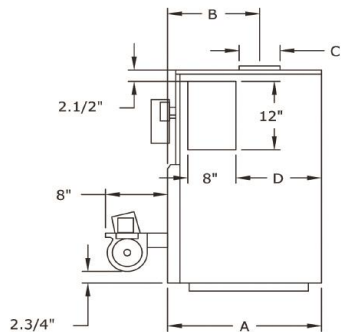

**General Information** (See IOM for complete instructions)

<b>Clearances</b>	<b>Combustible Materials (Required) (1)</b>	
	<b>Top</b>	24" (610 mm)
	<b>Front</b>	24" (610 mm)
	<b>Flue Connector</b>	9" (229 mm)
	<b>Rear</b>	6" (152 mm)
	<b>Left Side</b>	6" (152 mm)
<b>(1) Required distances measured from boiler.</b>	<b>Right Side</b>	24" (610 mm)
	<b>Connections (All Models)</b>	Return/Supply Tappings 1-1/4" NPT, Oil Line 3/8" O.D. copper tubing for runs of 50 feet or less, and 1/2" O.D. for longer runs.
<b>Electrical</b>	120 Volts AC, 60 hertz, 1 phase, Less than 12 amps (15 amp circuit recommended)	

**Tankless Heater Capacities**

Model	Input Rate G.P.H.	Tankless Heater Number	Tankless Heater Capacity Intermittent Draw G.P.M.	Boiler Water Content (Gallons)
BC3095	0.95	L-24	3.25	6.7
BC4100	1.00		3.25	8.2
BC4115	1.15		4.0	8.2

**Dimensions**

Model	A (Length of Flush Jacket)	B (Front of Jacket to Center Line of Flue Outlet)	C (Flue Outlet Diameter)	D (Tankless Coil to Back of Jacket)
BC3095	19"	9-3/4"	6"	8-7/8"
BC4100	23"	11-3/4"	6"	12-3/4"
BC4115	23"	11-3/4"	6"	12-3/4"

BC SERIES II CONTINUED										
(BECKETT BURNER - CHIMNEY VENTED - WITH COIL - LESS PUMP)										
BOILER MODEL	ITEM NUMBER	TRADE PRICE	FIR. RATE	INPUT (MBH)	HTG. CAP. (MBH)	AHRI NET (MBH)	AFUE RATING %	CHIMNEY SIZE	FLUE DIA.	SHIP WGT.
BC3095	BCB309532100210	\$2,779	0.95	133	114	99	84.0	8"x 8"x15'	6"	345
BC4100	BCB410032100210	\$3,092	1.00	140	121	105	85.0		6"	404
(BECKETT BURNER - CHIMNEY VENTED - WITH COIL - WITH TACO SYSTEM PUMP)										
BOILER MODEL	ITEM NUMBER	TRADE PRICE	FIR. RATE	INPUT (MBH)	HTG. CAP. (MBH)	AHRI NET (MBH)	AFUE RATING %	CHIMNEY SIZE	FLUE DIA.	SHIP WGT.
BC3095	BCB309532110210	\$2,855	0.95	133	114	99	84.0	8"x 8"x15'	6"	345
BC4100	BCB410032110210	\$3,169	1.00	140	121	105	85.0		6"	404
BC4115	BCB411532110210	\$3,169	1.15	161	137	119	84.0		6"	404
(BECKETT BURNER - CHIMNEY VENTED - WITH COIL - WITH GRUNDFOS SYSTEM PUMP)										
BOILER MODEL	ITEM NUMBER	TRADE PRICE	FIR. RATE	INPUT (MBH)	HTG. CAP. (MBH)	AHRI NET (MBH)	AFUE RATING %	CHIMNEY SIZE	FLUE DIA.	SHIP WGT.
BC3095	BCB309532120210	\$2,855	0.95	133	114	99	84.0	8"x 8"x15'	6"	345
BC4100	BCB410032120210	\$3,169	1.00	140	121	105	85.0		6"	404
(BECKETT BURNER - CHIMNEY VENTED - LESS COIL - LESS PUMP)										
BOILER MODEL	ITEM NUMBER	TRADE PRICE	FIR. RATE	INPUT (MBH)	HTG. CAP. (MBH)	AHRI NET (MBH)	AFUE RATING %	CHIMNEY SIZE	FLUE DIA.	SHIP WGT.
BC3095	BCB309531100210	\$2,525	0.95	133	114	99	84.0	8"x 8"x15'	6"	345
BC4100	BCB410031100210	\$2,836	1.00	140	121	105	85.0		6"	404
(BECKETT BURNER - CHIMNEY VENTED - LESS COIL - WITH TACO SYSTEM PUMP)										
BOILER MODEL	ITEM NUMBER	TRADE PRICE	FIR. RATE	INPUT (MBH)	HTG. CAP. (MBH)	AHRI NET (MBH)	AFUE RATING %	CHIMNEY SIZE	FLUE DIA.	SHIP WGT.
BC3095	BCB309531110210	\$2,602	0.95	133	114	99	84.0	8"x 8"x15'	6"	345
BC4100	BCB410031110210	\$2,912	1.00	140	121	105	85.0		6"	404
BC4115	BCB411531110210	\$2,912	1.15	161	137	119	84.0		6"	404
(BECKETT BURNER - CHIMNEY VENTED - LESS COIL - WITH GRUNDFOS SYSTEM PUMP)										
BOILER MODEL	ITEM NUMBER	TRADE PRICE	FIR. RATE	INPUT (MBH)	HTG. CAP. (MBH)	AHRI NET (MBH)	AFUE RATING %	CHIMNEY SIZE	FLUE DIA.	SHIP WGT.
BC3095	BCB309531120210	\$2,602	0.95	133	114	99	84.0	8"x 8"x15'	6"	345
BC4100	BCB410031120210	\$2,912	1.00	140	121	105	85.0		6"	404

**(USE PARTS MULTIPLIER FOR ALL OF THE FOLLOWING)**

	PN	TRADE
BC4100 RERATE KIT - BC4115 to 1.00 GPH	550002656	\$40
BC4115 RERATE KIT - BC4100 to 1.15 GPH	550002657	\$32

**BC SERIES II - STANDARD EQUIPMENT**

**STANDARD EQUIPMENT:**

- Boiler Controls: High Limit, Circulator Control and Primary Control.
- Heat Exchanger: Cast Iron Heat Exchanger with Cast Iron Push Nipples.
- Combustion: Beckett Oil Burner, Combustion Chamber with Target Wall/Liner.
- Electrical: Wiring Harness, Burner Electrical Disconnect.
- Safety: 30 PSI A.S.M.E. Safety Relief Valve.
- Other: Crated Cast Iron Boiler with Insulated Flush Jacket; Circulator - 1-1/4", Temperature Pressure Gauge, Boiler Drain Valve, 1-1/4" Supply and Return Tapping.
- For Tankless Heater Units: Tankless Hot Water Coil and Low Limit.

**H2O SERIES**  
 STAINLESS STEEL  
 SINGLE COIL  
 INDIRECT WATER HEATER

**H2O I 30 L UB**

I=Indirect  
 Capacity:  
 30=30 Gals.  
 40=40 Gals.  
 50=50 Gals.  
 60=60 Gals.  
 80=80 Gals.  
 85=87 Gals.  
 115=115 Gals.  
 L=Lowboy  
 C=Commercial  
 HO=High Output  
 HOC=High Output Commercial  
 XHO=Extra High Output  
 UB=Utica Boiler



Conforms to UL STD 174  
 Certified to CAN/CSA STD C22.2 No. 110-94

**STANDARD AND HO UNITS**

**HOC UNITS**

**XHOC EXTRA HIGH OUTPUT UNITS**

Note: Max. Working pressure 150 psi for all capacities.

**General Information (See IOM for complete instructions)**

Model	Piping Connections NPT		Height (Inches)	Dia. (Inches)
	Domestic Water In/Out (Inches)	Boiler Water In/Out (Inches)		
H2OI30UB	3/4	1	34.0	23.5
H2OI40UB	3/4	1	44.0	23.5
H2OI40LUB	3/4	1	36.0	28.0
H2OI50UB	3/4	1	54.0	23.5
H2OI60UB	3/4	1	62.0	23.5
H2OI60LUB	3/4	1	46.0	28.0
H2OI80UB	1	1	56.0	28.0
H2OI115UB	1	1	74.0	28.0
H2OI60HOUB	1	1	62.0	23.5
H2OI80HOUB	1	1	56.0	28.0
H2OI80HOCUB	1-1/2	1-1/4	56.0	28.0
H2OI115HOUB	1	1	74.0	28.0
H2OI115HOCUB	1-1/2	1-1/4	74.0	28.0
H2OI85XHOCUB	1-1/2	1-1/2	64.0	28.0
H2OI115XHOCUB	1-1/2	1-1/2	74.0	28.0

H2O SINGLE COIL STAINLESS STEEL INDIRECT WATER HEATERS CONTINUED							
MODEL	TRADE PRICE	STOR. CAP. (Gals.)	DESCRIPTION	MAX. FIRST HOUR RATING Gal./Hr. @		BOILER OUTPUT REQ. (BTU/Hr.)	SHP. WGT. (LBS.)
				140°F	115°F		
H2OI30UB	\$1,389	30	STANDARD	202	269	131,250	85
H2OI40UB	\$1,429	40	STANDARD	221	292	138,670	100
H2OI40LUB	\$1,522	42	LOWBOY	212	251	132,000	100
H2OI50UB	\$1,725	50	STANDARD	223	291	133,280	110
H2OI60UB	\$2,063	60	STANDARD	262	342	155,700	125
H2OI60LUB	\$2,122	60	LOWBOY	239	310	138,570	120
H2OI80UB	\$2,288	80	STANDARD	271	248	149,390	140
H2OI115UB	\$3,395	115	STANDARD	324	409	165,750	175
H2OI60HOUB	\$2,225	60	HIGH OUTPUT	406	541	263,600	145
H2OI80HOUB	\$3,093	80	HIGH OUTPUT	418	551	259,640	155
H2OI80HOCUB	\$3,338	80	HIGH OUTPUT COMMERCIAL	442	584	227,070	155
H2OI115HOUB	\$4,183	115	HIGH OUTPUT	467	607	273,100	190
H2OI115HOCUB	\$4,429	115	HIGH OUTPUT COMMERCIAL	479	623	281,300	190
H2OI85XHOCUB	\$4,157	87	EXTRA HIGH OUTPUT	738	992	495,000	215
H2OI115XHOCUB	\$4,934	115	EXTRA HIGH OUTPUT	763	1017	495,000	240

**H2O SINGLE COIL INDIRECT WATER HEATERS WITH ELECTRIC BACKUP (3500 WATTS)**

MODEL	TRADE PRICE	STOR. CAP. (Gals.)	DESCRIPTION	MAX. FIRST HOUR RATING Gal./Hr. @		SHP. WGT. (LBS.)
				140°F	115°F	
H2OI60EUB	\$2,897	60	ELECTRIC BACK-UP	254	333.0	135
H2OI80EUB	\$3,241	80	ELECTRIC BACK-UP	266	341.0	145
H2OI115EUB	\$4,492	115	ELECTRIC BACK-UP	319	403.0	180

**H2O SINGLE COIL STANDARD EQUIPMENT**

**Standard Equipment:** Factory installed brass drain and relief valves, welded stainless steel cold water dip tube factory installed and pressure tested, Honeywell L4080B aquastat for field installation and magnesium anode rod(s).

**H2O SINGLE COIL OPTIONS**

**Options:** (L) Low Profile, (C) Commercial, (HO) High Output, (HOC) High Output Commercial, (XHO) Extra High Output, (E) Electric Backup

**H2O SERIES**

STAINLESS STEEL  
DUAL COIL SOLAR  
INDIRECT WATER HEATER



**H2O**

**I**  
I = Indirect

**60**  
Capacity:  
60 = 60 Gals.  
80 = 80 Gals.  
115 = 115 Gals.

**D**  
D = Dual Coil

**E**  
E = Electrical  
Back up  
(3500Watt)

**UB**  
UB = Utica Boiler

Conforms to UL STD 174

**Intertek**

Certified to CAN/CSA STD C22.2 No. 110-94

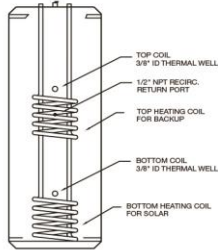
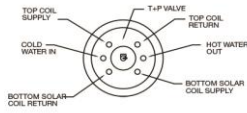

DUAL COIL UNITS

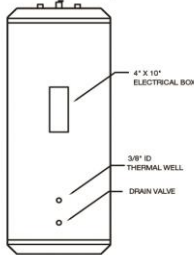
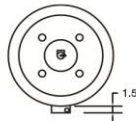

ELECTRIC BACKUP UNITS



Note: Max. Working pressure 150 psi for all capacities.

**General Information** (See IOM for complete instructions)

Model	Piping Connections NPT (Inches)	Height (Inches)	Dia. (Inches)
H2O160DUB	1	62.0	23.5
H2O180DUB	1	56.0	28.0
H2O115DUB	1	74.0	28.0
H2O160DEUB	1	62.0	23.5
H2O180DEUB	1	56.0	28.0
H2O115DEUB	1	74.0	28.0

**H2O DUAL COIL STAINLESS STEEL INDIRECT WATER HEATERS CONTINUED**

MODEL	TRADE PRICE	STOR. CAP. (Gals.)	DESCRIPTION	RECOVERY RATE GAL./HR.		SHP. WGT. (LBS.)
				TOP COIL	BOTTOM COIL	
H2OI60DUB	\$2,738	60	DUAL COIL INDIRECT	185	214	165
H2OI80DUB	\$3,117	80	DUAL COIL INDIRECT	180	214	175
H2OI115DUB	\$3,993	115	DUAL COIL INDIRECT	190	214	205

**H2O DUAL COIL STAINLESS STEEL INDIRECT WATER HEATERS WITH ELECTRIC BACKUP (3500 WATTS)**

MODEL	TRADE PRICE	STOR. CAP. (Gals.)	DESCRIPTION	RECOVERY RATE GAL./HR.		SHP. WGT. (LBS.)
				TOP COIL	BOTTOM COIL	
H2OI60DEUB	\$3,381	60	DUAL COIL ELECTRIC BACK-UP	185	214	175
H2OI80DEUB	\$3,820	80	DUAL COIL ELECTRIC BACK-UP	180	214	185
H2OI115DEUB	\$4,792	115	DUAL COIL ELECTRIC BACK-UP	190	214	215

**H2O DUAL COIL STANDARD EQUIPMENT**

**Standard Equipment:** Factory installed brass drain and relief valves, welded stainless steel cold water dip tube factory installed and pressure tested, Honeywell L4080B aquastat for field installation and magnesium anode rod(s). Removable thermal well to accept a solar control thermostat or thermistor. Dual coil units equipped with two aquastat wells which control each coil independently and built-in recirculation tapping. Units with Electric Back-Up are provided with 4" x 10" electrical box with pre-wired heating element, thermostat, and hi-limit. All electric back-up units provided with 240 volt AC, 3500 watt element.

**H2O DUAL COIL OPTIONS**

**Options:** (E) Electric Backup models for supplemental heating.



**H2O SERIES**  
STAINLESS STEEL  
STORAGE TANKS



**Intertek**

Conforms to UL STD 174  
Certified to CAN/CSA STD C22.2 No. 110-94

**H2O ST 30 L UB**

ST=Storage Tank

Capacity:  
30=30 Gals.  
40=40 Gals.  
60=60 Gals.  
80=80 Gals.  
115=115 Gals.

L=Lowboy  
C=Commercial

UB=Utica Boiler

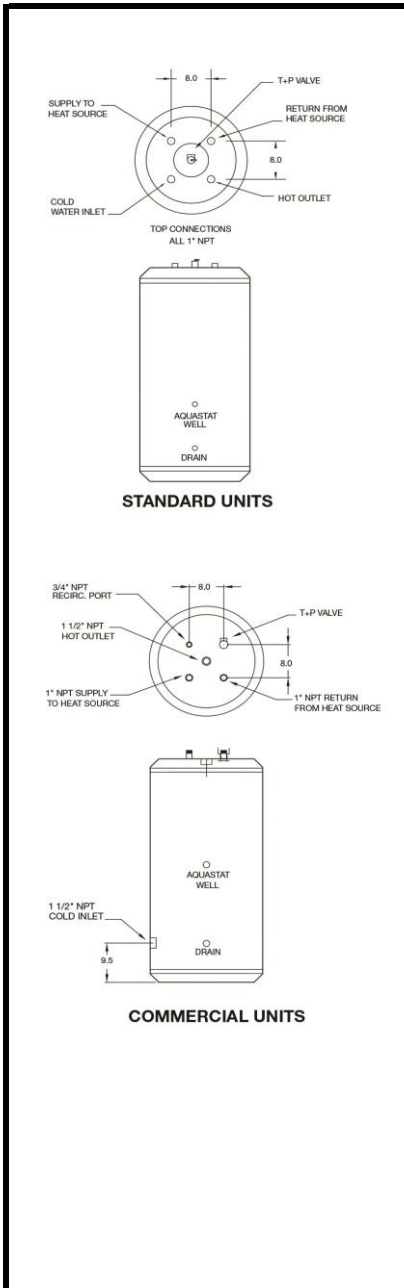

Note: Max. Working pressure 150 psi for all capacities.

**General Information** (See IOM for complete instructions)

Model	Piping Connections NPT		Height (Inches)	Dia. (Inches)
	Supply/Return (Inches)	Heat Source Pressure (Inches)		
H2OST30UB	1	1	34.0	23.5
H2OST40UB	1	1	44.0	23.5
H2OST60UB	1	1	62.0	23.5
H2OST60LUB	1	1	46.0	23.5
H2OST80UB	1	1	56.0	28.0
H2OST115UB	1	1	74.0	28.0
H2OST80CUB	1-1/2	1	56.0	28.0
H2OST115CUB	1-1/2	1	74.0	28.0

H2O STAINLESS STEEL HOT WATER STORAGE TANKS (NO COIL) CONTINUED				
MODEL	TRADE PRICE	STOR. CAP. (Gals.)	DESCRIPTION	SHP. WGT. (LBS.)
H2OST30UB	\$1,233	30	H2O HOT WATER STORAGE TANK (NO COIL)	75
H2OST40UB	\$1,275	40	H2O HOT WATER STORAGE TANK (NO COIL)	90
H2OST60UB	\$1,858	60	H2O HOT WATER STORAGE TANK (NO COIL)	115
H2OST60LUB	\$1,919	60	LOW BOY H2O HOT WATER STORAGE TANKS (NO COIL)	110
H2OST80UB	\$2,112	80	H2O HOT WATER STORAGE TANKS (NO COIL)	140
H2OST80CUB	\$3,042	80	COMM. H2O HOT WATER STORAGE TANK (NO COIL)	175
H2OST115UB	\$2,323	115	H2O HOT WATER STORAGE TANK (NO COIL)	140
H2OST115CUB	\$3,254	115	COMM. H2O HOT WATER STORAGE TANK (NO COIL)	175
H2O STORAGE TANK STANDARD EQUIPMENT				
<b>Standard Equipment:</b> Factory installed brass drain and relief valves, welded stainless steel cold water dip tube factory installed and pressure tested, Honeywell L4080B aquastat for field installation.				
H2O STORAGE TANK OPTIONS				
<b>Options:</b> (C) Commercial, (L) Low Profile				

**H2O SERIES**  
STAINLESS STEEL  
BUFFER TANKS

**H2O BT 40 114 WC UB**

BT = Buffer Tank

Capacity:  
22 = 22 Gals.  
40 = 40 Gals.  
60 = 60 Gals.  
80 = 80 Gals.

114 = 1-1/4" NPT  
112 = 1-1/2" NPT  
2 = 2" NPT

WC = With Coil

UB = Utica Boiler



Conforms to UL STD 174  
Certified to CAN/CSA STD C22.2 No. 110-94

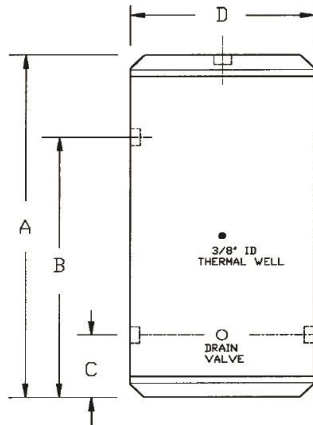

4 CONNECTIONS  
1 ON RIGHT SIDE  
2 ON LEFT SIDE  
1 ON TOP



Note: Max. Working pressure 150 psi for all capacities.

**General Information** (See IOM for complete instructions)

Model	Piping Connections NPT (Inches)	Height (Inches)	B (Inches)	C (Inches)
H2OBT22114UB	1-1/4	24.5	15	8
H2OBT40114UB	1-1/4	42.0	31.0	11.0
H2OBT40112UB	1-1/2			
H2OBT402UB	2	44.0	31.5	11.5
H2OBT60114UB	1-1/4			
H2OBT60112UB	1-1/2			
H2OBT602UB	2	54	40.5	11.5
H2OBT80114UB	1-1/4			
H2OBT80112UB	1-1/2			
H2OBT802UB	2	72	61.5	11.5
H2OBT115114UB	1-1/4			
H2OBT115112UB	1-1/2			
H2OBT1152UB	2	42.0	31.0	11.0
H2OBT40114WCUB	1-1/4			
H2OBT40112WCUB	1-1/2			
H2OBT402WCUB	2	44.0	31.5	11.5
H2OBT60114WCUB	1-1/4			
H2OBT60112WCUB	1-1/2			
H2OBT602WCUB	2	54	40.5	11.5
H2OBT80114WCUB	1-1/4			
H2OBT80112WCUB	1-1/2			
H2OBT802WCUB	2	72	61.5	11.5
H2OBT115114WCUB	1-1/4			
H2OBT115112WCUB	1-1/2			
H2OBT1152WCUB	2			

**H2O HYDRONIC STAINLESS STEEL BUFFER TANKS CONTINUED**

MODEL	TRADE PRICE	STOR. CAP. (Gals.)	DESCRIPTION	SHP. WGT. (LBS.)
H2OBT22114UB	\$1,236	22	HYDRONIC BUFFER TANK	35
H2OBT40114UB	\$2,162	40	HYDRONIC BUFFER TANK	87
H2OBT40112UB	\$2,162			
H2OBT402UB	\$2,162			
H2OBT60114UB	\$2,575	60	HYDRONIC BUFFER TANK	115
H2OBT60112UB	\$2,575			
H2OBT602UB	\$2,575			
H2OBT80114UB	\$2,842	80	HYDRONIC BUFFER TANK	125
H2OBT80112UB	\$2,842			
H2OBT802UB	\$2,842			
H2OBT115114UB	\$3,539	115	HYDRONIC BUFFER TANK	160
H2OBT115112UB	\$3,539			
H2OBT1152UB	\$3,539			

**H2O HYDRONIC BUFFER TANKS (WITH COIL)**

MODEL	TRADE PRICE	STOR. CAP. (Gals.)	DESCRIPTION	SHP. WGT. (LBS.)
H2OBT40114WCUB	\$2,772	40	HYDRONIC BUFFER TANK (WITH COIL)	97
H2OBT40112WCUB	\$2,773			
H2OBT402WCUB	\$2,772			
H2OBT60114WCUB	\$3,224	60	HYDRONIC BUFFER TANK (WITH COIL)	125
H2OBT60112WCUB	\$3,224			
H2OBT602WCUB	\$3,224			
H2OBT80114WCUB	\$3,516	80	HYDRONIC BUFFER TANK (WITH COIL)	135
H2OBT80112WCUB	\$3,516			
H2OBT802WCUB	\$3,516			
H2OBT115114WCUB	\$4,280	115	HYDRONIC BUFFER TANK (WITH COIL)	170
H2OBT115112WCUB	\$4,280			
H2OBT1152WCUB	\$4,280			

**H2O BUFFER TANK STANDARD EQUIPMENT**

**Standard Equipment:** Factory installed brass drain and relief valves, welded stainless steel cold water dip tube factory installed and pressure tested, Honeywell L4080B aquastat for field installation.

**H2O BUFFER TANK OPTIONS**

**Options:** (WC) With Coil

**HOTLINE SERIES**

**INDIRECT WATER HEATER**

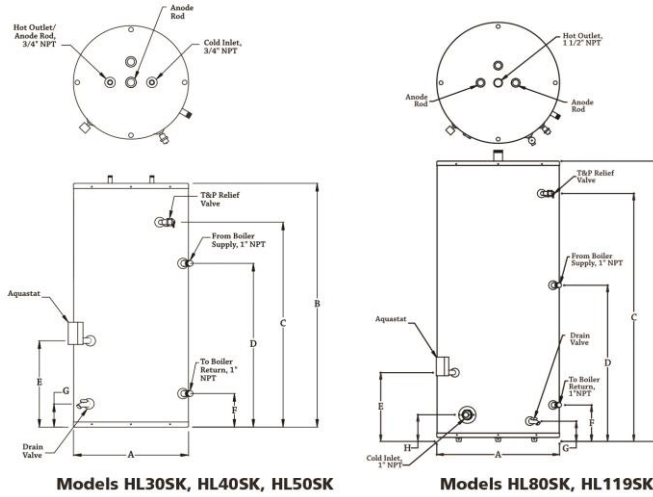

Note: Max. Working pressure 150 psi for all capacities.

**General Information** (See IOM for complete instructions)

Model	Piping Connections NPT		A Dia. (Inches)	B Height (Inches)
	Domestic Water In/Out (Inches)	Boiler Water In/Out (Inches)		
*ST00211	3/4	1	22.0	35-3/4
ST00215	3/4	1	22.0	42-3/4
ST00212	3/4	1	22.0	48-3/4
ST00213	1	1	24.0	64-3/4
ST00214	1	1	28.0	65-1/4

**HOTLINE INDIRECT WATER HEATERS**

MODEL	NAME	TRADE PRICE	STOR. CAP. (Gals.)	BTU/H MIN. BOILER OUTPUT	MAX 1ST HR FLOW RATINGS GAL./HR.	SHP. WGT. (LBS.)
*ST00211	HL30SK	\$1,233	30	74	115	140
ST00215	HL40SK	\$1,359	40	74	125	200
ST00212	HL50SK	\$1,496	50	74	140	220
ST00213	HL80SK	\$2,134	80	150	185	286
ST00214	HL119SK	\$2,614	119	175	250	372

\*SURFACE MOUNTED THERMOSTAT.

HOTLINE OPTIONS/ADDITIONAL EQUIPMENT	PN	TRADE
MAGNESIUM ANODE 3/4 X 30; 30-40-50 GAL.	ST00301	\$63
MAGNESIUM ANODE 3/4 X 36; 80 GAL.	ST00701	\$51
MAGNESIUM ANODE 3/4 X 36; 119 GAL.	ST00901	\$42
DIP TUBE 3/4 X 3 X 33; 30 GAL.	ST00401	\$72
DIP TUBE 3/4 X 3 X 38; 40 GAL.	ST01301	\$16
DIP TUBE 3/4 X 3 X 44; 50 GAL.	ST00801	\$31
T & P VALVE 3/4, LL100XL; 30-40-50 GAL.	ST00601	\$37
T & P VALVE 3/4, 140X5; 80-119 GAL.	ST01001	\$90
AQUASTAT L4080B1352	ST01101	\$324

**HOTLINE INDIRECT WATER HEATER STANDARD EQUIPMENT**

**STANDARD EQUIPMENT:** Factory Assembled Hot Water Tank; Steel Tank with 2" Foam Insulation; Smooth Coil Coated with Porcelain to resist Corrosion and Lime Build-Up; Replaceable Magnesium Anode Rod Aquastat Limit Control; Self Cleaning Drain Valve; Factory Installed T & P Valve.