



WIRING INSTRUCTIONS FOR ARM-6P

The ARM-6P circulator relay is controlled by low voltage thermostat or any other low voltage controllers having a SPST switching action. The relays provide intermediate switching to permit one of six separate line voltage loads (circulators) and Separate Expansion Module (AD-1 and AD-4) can be connected to ARM-6P to operate up to 15 zones. Advanced circuit design will operate with most battery powered (not battery backup) digital thermostats.

The isolated and switch relay terminals X-X has a full 10 amp current rating.

When a zone calls for heat (TT terminals are connected), the following operation sequence occurs:

1. Isolated switch relay closes.
2. X-X and switch is closed.
3. X-X Indicator light turns on.
4. Control relay closes.
5. Zone circulator will start.

If Priority Switch is in ON position

1. Zone 1 becomes priority zone.
2. Circulator for zone 2, 3, 4, and any modules will not operate when zone 1 (Priority) circulator is actuated.

Consult Instruction Sheet for AD-1 and AD-4, Data Part connection, Wiring Diagrams and transformer replacement.

All wiring must be copper and comply with applicable electrical codes including wire size, type of installation an enclosure electrical rating. Torque terminal screws 6 to 7 inch lbs. This device intended to be connected by an isolated ground and to be connected to a metal enclosure wiring systems. ALL PRIMARY wiring to be 14 AWG MINIMUM.

NOTE: Cold Start Boiler- Factory installed jumper to be removed from terminals.

Tankless Coil Boiler- Factory Installed jumper to be removed from ZC/ZR terminals. Connect ZC/ZR to corresponding terminals on Aquastat Relay (eg.MHL8124).

SPECIFICATION

Zones	Transformer Voltage	Relay Switching Action	Thermostat Current	Single Phase Motor Rating
				120V AC 1/3 HP (Each Circuit)
6	120 V 60 HZ 30 VA	DPST	.085	

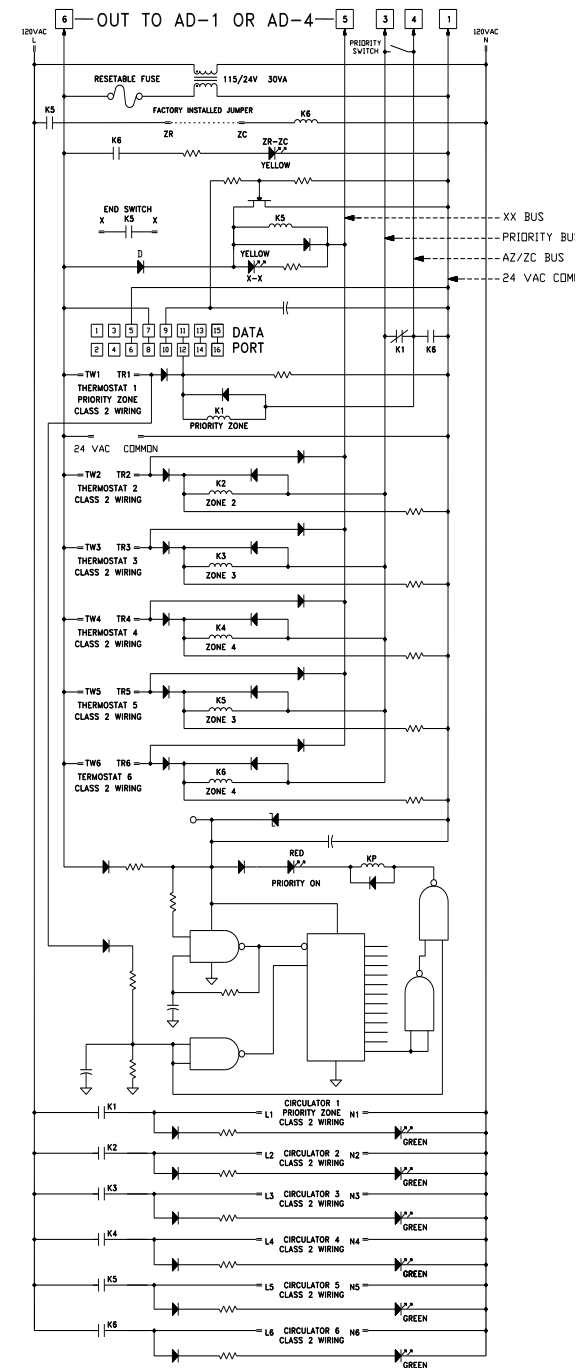

2201 Dwyer Avenue, Utica, NY 13501
Tel. 800 253 7900
www.ecrinternational.com

All specifications subject to change without notice.
©2018 ECR International, Inc.
PN W77 REV. C [03/01/2018]